



PCD200 - Premium Choice High Volume Fan with DC Motor

(Ceiling Mounted Ventilation Fans)



Performance & Dimensions

Static Pressure (inches w.g.)	0.1	0.25
CFM	200	195
Sones	2.4	N/A
Watts	31W	
ENERGY STAR Qualified	Yes	
Duct Connector Diameter (in)	6"	
Grille Size (in)	15" x 16"	
Dimensions (w x d x h) (in)	12-7/8" x 12-1/2" x 7-5/8"	

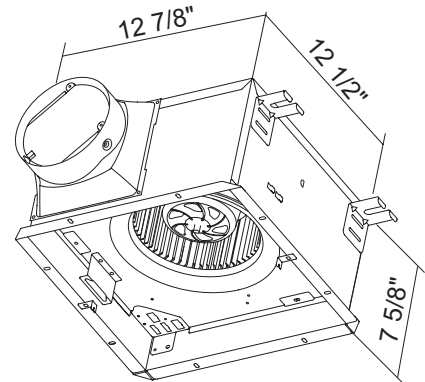

Optional Accessories:

- Humidity Sensor

Typical Specifications:

Ventilating fan shall be S&P PCD200 mounted in the ceiling. The DC motor shall have a 6-year warranty, and the fan shall have a 5-year limited warranty. The fan shall be HVI Certified at 0.1 inch water gauge for CFM performance above. The motor shall be ETL and cETL Listed with impedance protection plus additional thermal protection. The fan shall be ENERGY STAR® Qualified.

