



L900L & L1500L

Losone Select Inline/Cabinet Ventilators

Incredibly reliable. Unbelievably quiet.
Offering the CFM choices you need at the lowest sound levels in the industry.

FEATURES:

Blower:

- Low RPM for quiet operation
- Resilient anti-vibration mounts
- Dynamically-balanced, polymeric, centrifugal blower wheel for quiet, efficient performance
- Permanently lubricated, thermally protected motor
- Plug-in motor rated at 120 VAC
- Designed for continuous operation

Housing:

- Rugged, galvanized steel
- 8" x 12" duct connectors
- May be installed in ceiling or wall (size permitting)
- 8-position mounting brackets for easy installation and greater adaptability to various mounting requirements
- Automatic backdraft damper located within duct connector
- Factory-shipped in horizontal discharge position for 8" x 12" ductwork
- May be converted to vertical discharge

TYPICAL SPECIFICATION:

Ventilator shall have galvanized steel housing. Housing to have adjustable mounting brackets.

Automatic backdraft damper to be located within duct connector. Duct connector, blower assembly and wiring plate shall be adjustable for either horizontal or vertical installation.

Blower unit shall be removable from housing and will have a metal, centrifugal-type blower wheel. Motor to be permanently lubricated and mounted with resilient antivibration mounts. RPM not to exceed number listed for each model.

Air delivery shall be no less and sound levels no greater than listed for each model. All air and sound ratings shall be certified by AMCA. Units to be cULus listed.

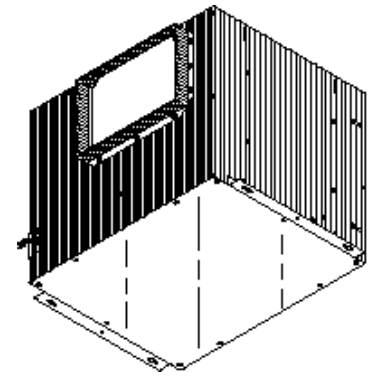

S&P USA Ventilation Systems, LLC, Div. of Soler & Palau Ventilation Group, certifies that the Losone Select Series shown herein are licensed to bear the AMCA Seal. The ratings shown are based on test and procedures performed in accordance with AMCA Publication 211 and AMCA Publication 311 and comply with the requirement of the AMCA Certified Ratings Program.



WEIGHT:

MODEL NO.	SHIPPING WEIGHT
L900L	64.4 lbs.
L1500L	64.5 lbs.

DIMENSIONS:

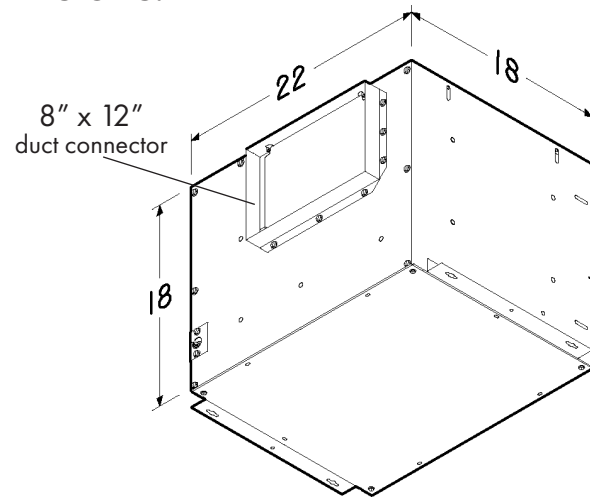



L900L & L1500L

Losone Select Inline/Cabinet Ventilators

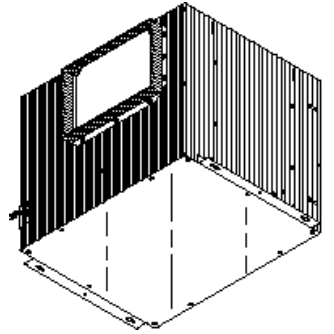

PERFORMANCE RATINGS:

AMCA LICENSED PERFORMANCE RATINGS

MODEL NO.	NOMINAL VOLTAGE	CFM/SONES - AT STATIC PRESSURES (Ps - inches of H ₂ O)											NOMINAL RPM	AMPS @ 60 Hz	WATTS
		0.0" Ps	.10" Ps	.125" Ps	.250" Ps	.375" Ps	.50" Ps	.625" Ps	.750" Ps	.875" Ps	1.0" Ps				
L900L	120 VAC	CFM St. Thr.	930	902	894	853	807	754	685	587	442	300	810	3.0	306
		Sones St. Thr.	3.7	3.8	3.8	3.8	3.7	3.8	3.9	4.0	4.0	4.1			
		CFM Rt Ang.	795	778	772	743	709	668	613	527	432	291	755	3.0	306
		Sones Rt Ang.	4.3	4.5	4.4	4.6	4.4	4.2	4.1	4.3	4.2	4.3			
L1500L	120 VAC	CFM St. Thr.	1275	1228	1214	1152	1092	1029	958	871	764	631	1055	5.9	468
		Sones St. Thr.	6.8	6.8	6.7	6.5	6.3	6.0	6.0	6.0	6.0	6.1			
		CFM Rt Ang.	1160	1117	1106	1051	998	928	856	769	657	499	1020	5.9	468
		Sones Rt Ang.	7.9	7.8	7.9	7.4	7.1	6.8	6.3	5.9	5.4	5.4			

Performance ratings include the effects of backdraft damper in the airstream. Speed (RPM) shown is nominal. Performance is based on actual speed of test.

The sound ratings shown are loudness values in fan sones at 5' (1.5m) in a hemispherical free field calculated per AMCA Std. 301. Values shown are for Installation Type D: Ducted inlet, Ducted outlet. Ratings do not include the effect of duct end correction. Performance ratings include the effects of 18 feet of round inlet duct and, if needed, a rectangular to round duct transition in the airstream. Performance shown is for Installation Type D: Ducted inlet, Ducted outlet.

AMCA
WORLDWIDE
CERTIFIED
RATINGS

SOUND
AND
AIR
PERFORMANCE

UL
LISTED

S&P USA Ventilation Systems, LLC., Div. of Soler & Palau Ventilation Group, certifies that the Losone Select Series shown herein are licensed to bear the AMCA Seal. The ratings shown are based on test and procedures performed in accordance with AMCA Publication 211 and AMCA Publication 311 and comply with the requirement of the AMCA Certified Ratings Program.

