

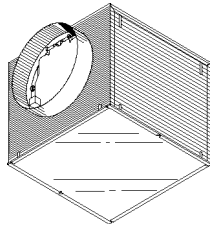

P: 800.961.7370
www.solerpalau-usa.com

SPECIFICATION SHEET

FFC200, FFC250 & FFC300 IN-LINE VENTILATORS



Incredibly reliable. Unbelievably quiet. Offering the CFM choices you need at the lowest sound levels in the industry.

FEATURES

BLOWER:

- Low RPM for quiet operation
- Resilient anti-vibration mounts
- Dynamically-balanced, polymeric, centrifugal blower wheel for quiet, efficient performance
- Permanently lubricated, thermally protected motor
- Plug-in motor rated at 120 VAC
- Designed for continuous operation

HOUSING:

- Rugged galvanized steel
- 8" round duct connectors
- May be installed in ceiling or wall (size permitting)
- 8-position mounting brackets for easy installation and greater adaptability to various mounting requirements
- Automatic backdraft damper located within duct connector
- Factory-shipped in horizontal discharge position - easily converted to vertical discharge
- Removable panel allows for easy motor access without disturbing ductwork
- Suitable for kitchen installations



Breidert Air Products, div. of Soler & Palau Ventilation Group, certifies that the models shown herein are licensed to bear the AMCA Seal. The ratings shown are based on tests and procedures performed in accordance with AMCA Publication 211 (and AMCA Publication 311 if sound is also certified) and comply with the requirements of the AMCA Certified Ratings Program.



TYPICAL SPECIFICATION

Ventilator shall have galvanized steel housing. Housing to have adjustable mounting brackets and removable panel to allow motor access without disturbing ductwork.

Automatic backdraft damper to be located within duct connector. Duct connector, blower assembly and wiring plate shall be adjustable for either horizontal or vertical installation.

Blower unit shall be removable from housing and will have a polymeric, dynamically balanced centrifugal-type blower wheel. Motor to be permanently lubricated and mounted with resilient anti-vibration mounts. RPM not to exceed number listed for each model.

Air delivery shall be no less and sound levels no greater than listed for each model. All air and sound ratings shall be certified by AMCA. Units to be cULus listed.

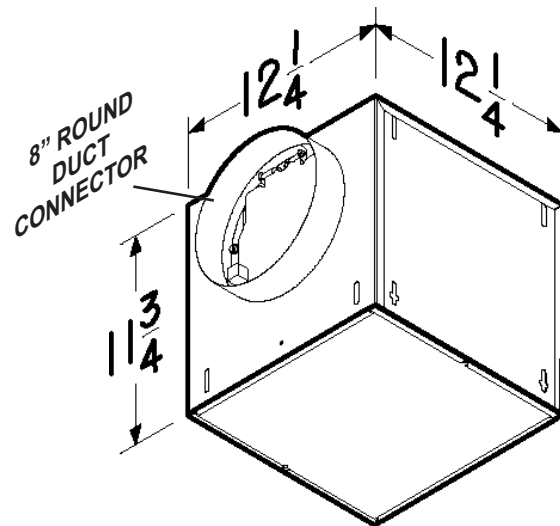

WEIGHT

MODEL NO.	SHIPPING WT.
FFC200	23.1 lbs.
FFC250	23.2 lbs.
FFC300	23.2 lbs.

PERFORMANCE RATINGS - IN-LINE VENTILATORS FFC200, FFC250 & FFC300

AMCA LICENSED PERFORMANCE RATINGS

MODEL NO.	NOMINAL VOLTAGE	CFM/SONES - AT STATIC PRESSURES (Ps - inches of H ₂ O)											NOMINAL RPM	AMPS @ 60 Hz	WATTS
		0.0"	.10"	.125"	.250"	.375"	.50"	.625"	.750"	.875"	1.0"				
		Ps	Ps	Ps	Ps	Ps	Ps	Ps	Ps	Ps	Ps				
FFC200	120 VAC	CFM St. Thr.	205	196	195	190	185	175	158	135	96	47	865	1.8	127
		SONES St. Thr.	1.7	1.9	1.9	2.1	2.3	2.4	3.0	3.3	3.4	3.4			
		CFM Rt. Ang.	183	177	176	170	163	152	137	121	96	51	930	1.8	127
		SONES Rt. Ang.	1.6	1.6	1.6	1.9	2.3	2.7	2.9	3.1	3.4	3.6			
FFC250	120 VAC	CFM St. Thr.	248	245	245	241	235	224	208	183	141	84	1005	2.1	166
		SONES St. Thr.	2.0	2.3	2.3	2.6	2.8	3.2	3.4	3.6	3.9	3.8			
		CFM Rt. Ang.	229	224	222	214	204	193	177	157	132	95	1115	2.1	166
		SONES Rt. Ang.	2.4	2.5	2.6	2.8	3.0	3.2	3.4	3.7	3.8	3.8			
FFC300	120 VAC	CFM St. Thr.	300	294	293	285	274	259	243	214	168	113	1145	2.6	212
		SONES St. Thr.	2.9	3.0	3.1	3.3	3.4	3.5	3.6	3.7	4.0	3.9			
		CFM Rt. Ang.	270	261	259	248	234	220	200	174	146	104	1285	2.6	212
		SONES Rt. Ang.	3.7	3.7	3.7	3.7	3.9	3.9	4.0	4.2	4.4	4.0			

Performance ratings include the effects of backdraft damper in the airstream. Speed (RPM) shown is nominal. Performance is based on actual speed of test. The sound ratings shown are loudness values in fan sones at 5' (1.5m) in a hemispherical free field calculated per AMCA Std. 301. Values shown are for Installation Type D: Ducted inlet, Ducted outlet. Ratings do not include the effect of duct end correction. Performance ratings include the effects of 18 feet of round inlet duct and, if needed, a rectangular to round duct transition in the airstream. Performance shown is for Installation Type D: Ducted inlet, Ducted outlet.



Breidert Air Products, div. of Soler & Palau Ventilation Group, certifies that the models shown herein are licensed to bear the AMCA Seal. The ratings shown are based on tests and procedures performed in accordance with AMCA Publication 211 (and AMCA Publication 311 if sound is also certified) and comply with the requirements of the AMCA Certified Ratings Program.

