

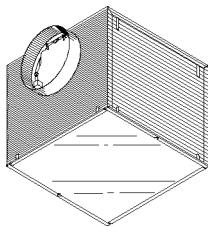

P: 800.961.7370  
www.solerpalau-usa.com

## SPECIFICATION SHEET



# FFC100 & FFC150 IN-LINE VENTILATORS

**Incredibly reliable. Unbelievably quiet. Offering the CFM choices you need at the lowest sound levels in the industry.**

### FEATURES

#### BLOWER:

- Low RPM for quiet operation
- Resilient anti-vibration mounts
- Dynamically-balanced, polymeric, centrifugal blower wheel for quiet, efficient performance
- Permanently lubricated, thermally protected motor
- Plug-in motor rated at 120 VAC
- Designed for continuous operation

#### HOUSING:

- Rugged, 20 gauge galvanized steel
- 6" round duct connectors
- May be installed in ceiling or wall (size permitting)
- 8-position mounting brackets for easy installation and greater adaptability to various mounting requirements
- Automatic backdraft damper located within duct connector
- Factory-shipped in horizontal discharge position - easily converted to vertical discharge
- Removable panel allows easy access to the motor without disturbing ductwork
- Suitable for kitchen installations

### TYPICAL SPECIFICATION

Ventilator shall have galvanized steel housing. Housing to have adjustable mounting brackets and removable panel to allow access to motor without disturbing ductwork.

Automatic backdraft damper to be located within duct connector. Duct connector, blower assembly and wiring plate shall be adjustable for either horizontal or vertical installation.

Blower unit shall be removable from housing and will have a polymeric, dynamically balanced centrifugal-type blower wheel. Motor to be permanently lubricated and mounted with resilient anti-vibration mounts. RPM not to exceed number listed for each model.

Air delivery shall be no less and sound levels no greater than listed for each model. All air and sound ratings shall be certified by AMCA. Units to be cULus listed.



Breidert Air Products, div. of Soler & Palau Ventilation Group, certifies that the models shown herein are licensed to bear the AMCA Seal. The ratings shown are based on tests and procedures performed in accordance with AMCA Publication 211 (and AMCA Publication 311 if sound is also certified) and comply with the requirements of the AMCA Certified Ratings Program.

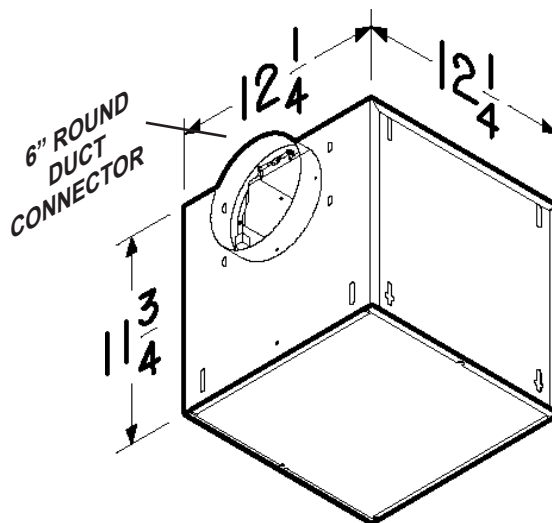

### WEIGHT

MODEL NO.	SHIPPING WT.
FFC100	22.9 lbs.
FFC150	22.9 lbs.

# PERFORMANCE RATINGS - IN-LINE VENTILATORS FFC100 & FFC150

## AMCA LICENSED PERFORMANCE RATINGS

MODEL NO.	NOMINAL VOLTAGE	CFM/SONES - AT STATIC PRESSURES (Ps - inches of H <sub>2</sub> O)										NOMINAL RPM	AMPS @ 60 Hz	WATTS	
		0.0"	.10"	.125"	.250"	.375"	.50"	.625"	.750"	.875"	1.0"				
		Ps	Ps	Ps	Ps	Ps	Ps	Ps	Ps	Ps	Ps				
FFC100	120 VAC	CFM St. Thr.	121	108	106	97	93	86	70	44	-	-	760	1.1	87
		SONES St. Thr.	0.5	0.7	0.7	1.1	1.4	1.8	2.1	2.4	-	-			
		CFM Rt. Ang.	109	98	96	88	82	78	67	48	16	-	780	1.1	87
		SONES Rt. Ang.	0.5	0.8	0.8	1.2	1.6	2.0	2.3	2.5	2.8	-			
FFC150	120 VAC	CFM St. Thr.	153	148	147	140	134	125	111	91	54	-	920	1.3	100
		SONES St. Thr.	0.9	1.0	1.1	1.4	1.6	1.9	2.1	2.2	2.4	-			
		CFM Rt. Ang.	144	138	137	131	123	114	102	83	54	17	950	1.3	100
		SONES Rt. Ang.	1.2	1.4	1.4	1.6	1.9	2.1	2.4	2.5	2.7	2.9			

Performance ratings include the effects of backdraft damper in the airstream. Speed (RPM) shown is nominal. Performance is based on actual speed of test. The sound ratings shown are loudness values in fan sones at 5' (1.5m) in a hemispherical free field calculated per AMCA Std. 301. Values shown are for Installation Type D: Ducted inlet, Ducted outlet. Ratings do not include the effect of duct end correction. Performance ratings include the effects of 18 feet of round inlet duct and, if needed, a rectangular to round duct transition in the airstream. Performance shown is for Installation Type D: Ducted inlet, Ducted outlet.



Breidert Air Products, div. of Soler & Palau Ventilation Group, certifies that the models shown herein are licensed to bear the AMCA Seal. The ratings shown are based on tests and procedures performed in accordance with AMCA Publication 211 (and AMCA Publication 311 if sound is also certified) and comply with the requirements of the AMCA Certified Ratings Program.

