

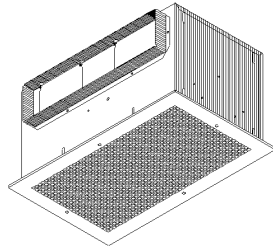

P: 800.961.7370  
www.solerpalau-usa.com

## SPECIFICATION SHEET



# FF400, FF500 & FF700 CEILING MOUNT VENTILATORS

**Incredibly reliable. Unbelievably quiet. Offering the CFM choices you need at the lowest sound levels in the industry.**

### FEATURES

#### GRILL:

- Conceals interior
- Low profile styling blends with any decor
- Metal, finished with white painted enamel

#### BLOWER:

- Low RPM for quiet operation
- Resilient anti-vibration mounts
- Balanced, polymeric, centrifugal blower wheel for quiet, efficient performance
- Permanently lubricated, thermally protected motor
- Plug-in motor rated at 120 VAC
- Designed for continuous operation

#### HOUSING:

- Rugged, 20 gauge galvanized steel
- 4½" x 18½" duct connector
- 1/2" acoustic insulation inside
- May be installed in ceiling or wall (size permitting)
- 8-position mounting brackets for easy installation and greater adaptability to various mounting requirements
- Automatic backdraft damper located within duct connector
- Factory-shipped in horizontal discharge position - easily converted to vertical discharge
- May be installed as an in-line ventilator with addition of accessory kit Model 982L

#### ACCESSORIES (purchase all separately):

- Model 423 Transition (4½" x 18½" to 10" round)
- Model RD2 Radiation Damper

### TYPICAL SPECIFICATION

Ventilator shall have galvanized steel housing insulated with at least 1/2" of acoustic insulation. Housing to have adjustable mounting brackets.

Automatic backdraft damper to be located within duct connector. Duct connector, blower assembly, and wiring plate shall be adjustable for either horizontal or vertical installation.

Blower unit shall be removable from housing and will have a polymeric, balanced centrifugal-type blower wheel. Motor to be permanently lubricated and mounted with resilient anti-vibration mounts. RPM not to exceed number listed for each model.

Air delivery shall be no less and sound levels no greater than listed for each model. All air and sound ratings shall be certified by AMCA. Units to be cULus listed.

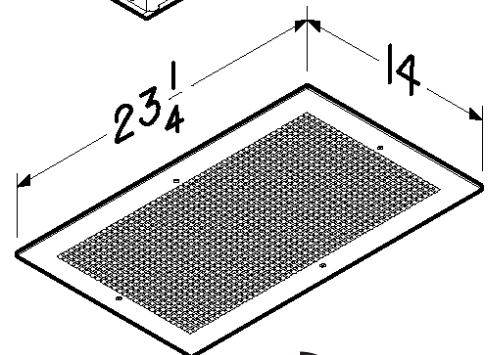
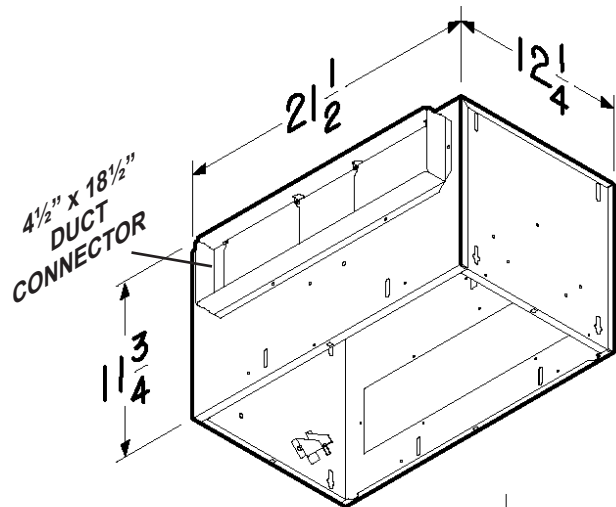

Breidert Air Products, div. of Soler & Palau Ventilation Group, certifies that the models shown herein are licensed to bear the AMCA Seal. The ratings shown are based on tests and procedures performed in accordance with AMCA Publication 211 (and AMCA Publication 311 if sound is also certified) and comply with the requirements of the AMCA Certified Ratings Program.



cULus listed for use over bathtubs and showers when connected to a GFCI-protected branch circuit.

### WEIGHT

MODEL NO.	SHIPPING WT.
FF400	33.8 lbs
FF500	33.8 lbs
FF700	33.9 lbs

# PERFORMANCE RATINGS - CEILING MOUNT VENTILATORS FF400, FF500 & FF700

## AMCA LICENSED PERFORMANCE RATINGS

MODEL NO.	NOMINAL VOLTAGE	CFM/SONES - AT STATIC PRESSURES (Ps - inches of H <sub>2</sub> O)										NOMINAL RPM	AMPS @ 60 Hz	WATTS	
		0.0" Ps	.10" Ps	.125" Ps	.250" Ps	.375" Ps	.50" Ps	.625" Ps	.750" Ps	.875" Ps	1.0" Ps				
FF400	120 VAC	CFM Hor.	480	442	434	388	344	299	229	182	114	-	735	1.4	146
		SONES Hor.	2.0	2.4	2.3	2.8	3.3	3.8	4.5	4.8	5.4	-			
		CFM Ver.	467	428	416	378	335	291	237	170	85	8	755	1.4	146
		SONES Ver.	2.3	2.6	2.6	3.0	3.5	4.0	5.1	5.5	5.7	5.9			
FF500	120 VAC	CFM Hor.	538	520	514	491	463	434	389	339	282	186	810	2.2	232
		SONES Hor.	3.0	3.1	3.3	3.6	4.0	4.4	5.0	5.7	6.2	6.7			
		CFM Ver.	539	517	512	481	451	418	367	319	247	137	865	2.2	232
		SONES Ver.	2.9	3.1	3.2	3.4	3.8	4.2	4.8	5.9	6.3	6.4			
FF700	120 VAC	CFM Hor.	722	704	701	667	640	607	571	534	453	333	960	2.9	313
		SONES Hor.	4.5	4.6	4.7	4.8	5.0	5.2	5.6	6.2	7.1	7.2			
		CFM Ver.	708	691	687	658	628	597	560	515	444	312	985	2.9	313
		SONES Ver.	5.2	5.0	5.0	5.7	5.8	6.1	6.4	7.4	7.1	7.6			

Performance ratings include the effects of inlet grill and backdraft damper in the airstream. Speed (RPM) shown is nominal. Performance is based on actual speed of test. The sound ratings shown are loudness values in fan sones at 5' (1.5m) in a hemispherical free field calculated per AMCA Std. 301. Values shown are for Installation Type B: Free inlet fan sone levels. Performance shown is for Installation Type B: Free inlet, Ducted outlet.



Breidert Air Products, div. of Soler & Palau Ventilation Group, certifies that the models shown herein are licensed to bear the AMCA Seal. The ratings shown are based on tests and procedures performed in accordance with AMCA Publication 211 (and AMCA Publication 311 if sound is also certified) and comply with the requirements of the AMCA Certified Ratings Program.



cULus listed for use over bathtubs and showers when connected to a GFCI-protected branch circuit.

