

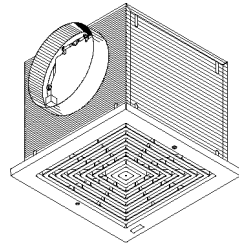

SPECIFICATION SHEET

FF200, FF250 & FF300 CEILING MOUNT VENTILATORS

P: 800.961.7370
www.solerpalau-usa.com



Incredibly reliable. Unbelievably quiet. Offering the CFM choices you need at the lowest sound levels in the industry.

FEATURES

GRILL:

- Conceals interior
- Low profile styling blends with any decor
- White polymeric

BLOWER:

- Low RPM for quiet operation
- Resilient anti-vibration mounts
- Dynamically-balanced, polymeric, centrifugal blower wheel for quiet, efficient performance
- Permanently lubricated, thermally protected motor
- Plug-in motor rated at 120 VAC
- Designed for continuous operation

HOUSING:

- Rugged, 20 gauge galvanized steel
- 8" round duct connector
- 1/2" acoustic insulation inside
- May be installed in ceiling or wall (size permitting)
- 8-position mounting brackets for easy installation and greater adaptability to various mounting requirements
- Automatic backdraft damper located within duct connector
- Factory-shipped in horizontal discharge position - easily converted to vertical discharge
- May be installed as an in-line ventilator with addition of accessory kit Model 981L

ACCESSORIES (purchase all separately):

- Model 981L In-line Adapter Kit
- Model RD1 Radiation Damper

TYPICAL SPECIFICATION

Ventilator shall have galvanized steel housing insulated with at least 1/2" of acoustic insulation. Housing to have adjustable mounting brackets.

Automatic backdraft damper to be located within duct connector. Duct connector, blower assembly, and wiring plate shall be adjustable for either horizontal or vertical installation.

Blower unit shall be removable from housing and will have a polymeric, dynamically balanced centrifugal-type blower wheel. Motor to be permanently lubricated and mounted with resilient anti-vibration mounts. RPM not to exceed number listed for each model.

Air delivery shall be no less and sound levels no greater than listed for each model. All air and sound ratings shall be certified by AMCA. Units to be cULus listed.

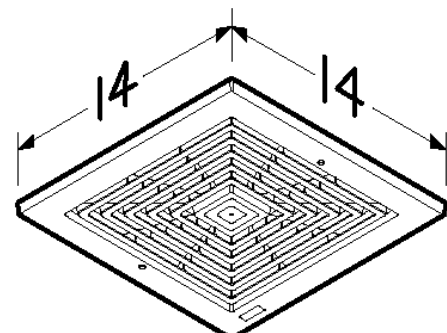
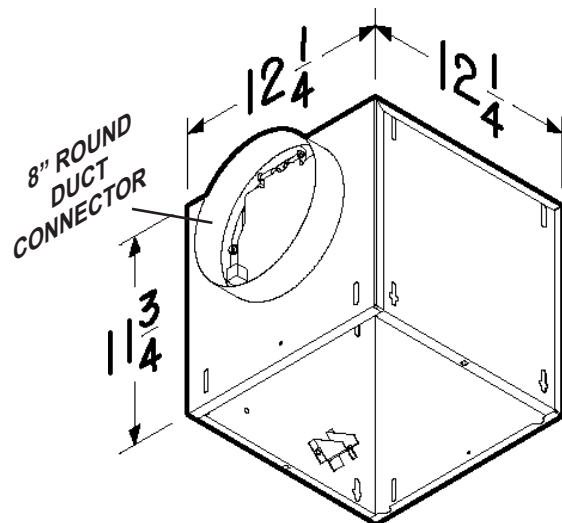

Breidert Air Products, div. of Soler & Palau Ventilation Group, certifies that the models shown herein are licensed to bear the AMCA Seal. The ratings shown are based on tests and procedures performed in accordance with AMCA Publication 211 (and AMCA Publication 311 if sound is also certified) and comply with the requirements of the AMCA Certified Ratings Program.



cULus listed for use over bathtubs and showers when connected to a GFCI-protected branch circuit.

WEIGHT

MODEL NO.	SHIPPING WT.
FF200	23.0 lbs
FF250	23.1 lbs
FF300	23.1 lbs

PERFORMANCE RATINGS - CEILING MOUNT VENTILATORS FF200, FF250 & FF300

AMCA LICENSED PERFORMANCE RATINGS

MODEL NO.	NOMINAL VOLTAGE	CFM/SONES - AT STATIC PRESSURES (Ps - inches of H ₂ O)										NOMINAL RPM	AMPS @ 60 Hz	WATTS	
		0.0"	.10"	.125"	.250"	.375"	.50"	.625"	.750"	.875"	1.0"				
		Ps	Ps	Ps	Ps	Ps	Ps	Ps	Ps	Ps	Ps				
FF200	120 VAC	CFM Hor.	231	214	210	196	186	177	165	144	113	51	740	1.8	127
		SONES Hor.	1.6	1.8	1.7	2.3	2.9	3.5	4.1	4.9	5.3	5.3			
		CFM Ver.	224	210	207	197	187	179	167	144	99	41	760	1.8	127
		SONES Ver.	1.5	1.8	2.0	2.3	2.7	3.4	4.0	4.5	5.1	5.2			
FF250	120 VAC	CFM Hor.	272	261	259	250	242	233	218	201	165	99	830	2.1	166
		SONES Hor.	2.1	2.3	2.2	2.9	3.3	3.9	4.4	4.8	5.5	5.8			
		CFM Ver.	269	261	259	253	248	239	224	203	171	101	860	2.1	166
		SONES Ver.	2.3	2.6	2.7	3.0	3.3	3.7	4.2	4.7	5.4	5.6			
FF300	120 VAC	CFM Hor.	312	309	308	303	296	287	273	254	219	125	905	2.6	212
		SONES Hor.	2.8	2.9	2.9	3.3	3.5	3.9	4.3	4.7	5.1	5.6			
		CFM Ver.	319	314	313	306	299	288	274	251	219	120	940	2.6	212
		SONES Ver.	2.6	2.9	3.0	3.4	3.6	3.9	4.4	4.7	5.0	5.5			

Performance ratings include the effects of inlet grill and backdraft damper in the airstream. Speed (RPM) shown is nominal. Performance is based on actual speed of test. The sound ratings shown are loudness values in fan sones at 5' (1.5m) in a hemispherical free field calculated per AMCA Std. 301. Values shown are for Installation Type B: free inlet fan sone levels. Performance shown is for Installation Type B: Free inlet, Ducted outlet.



Breidert Air Products, div. of Soler & Palau Ventilation Group, certifies that the models shown herein are licensed to bear the AMCA Seal. The ratings shown are based on tests and procedures performed in accordance with AMCA Publication 211 (and AMCA Publication 311 if sound is also certified) and comply with the requirements of the AMCA Certified Ratings Program.



cULus listed for use over bathtubs and showers when connected to a GFCI-protected branch circuit.

