

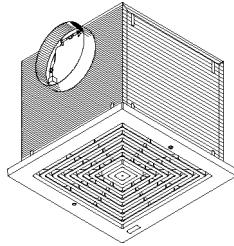

P: 800.961.7370
www.solerpalau-usa.com

FF100 & FF150 CEILING MOUNT VENTILATORS

SPECIFICATION SHEET



Incredibly reliable. Unbelievably quiet. Offering the CFM choices you need at the lowest sound levels in the industry.

FEATURES

GRILL:

- Conceals interior
- Low profile styling blends with any decor
- White polymeric

BLOWER:

- Low RPM for quiet operation
- Resilient anti-vibration mounts
- Dynamically-balanced, polymeric, centrifugal blower wheel for quiet, efficient performance
- Permanently lubricated, thermally protected motor
- Plug-in motor rated at 120 VAC
- Designed for continuous operation

HOUSING:

- Rugged, 20 gauge galvanized steel
- 6" round duct connector
- 1/2" acoustic insulation inside
- May be installed in ceiling or wall (size permitting)
- 8-position mounting brackets for easy installation and greater adaptability to various mounting requirements
- Automatic backdraft damper located within duct connector
- Factory-shipped in horizontal discharge position - easily converted to vertical discharge
- May be installed as an in-line ventilator with addition of accessory kit Model 961L

ACCESSORIES (purchase all separately):

- Model 961L In-line Adapter Plate
- Model RD1 Radiation Damper

TYPICAL SPECIFICATION

Ventilator shall have galvanized steel housing insulated with at least 1/2" of acoustic insulation. Housing to have adjustable mounting brackets.

Automatic backdraft damper to be located within duct connector. Duct connector, blower assembly and wiring plate shall be adjustable for either horizontal or vertical installation.

Blower unit shall be removable from housing and will have a polymeric, dynamically balanced centrifugal-type blower wheel. Motor to be permanently lubricated and mounted with resilient anti-vibration mounts. RPM not to exceed number listed for each model.

Air delivery shall be no less and sound levels no greater than listed for each model. All air and sound ratings shall be certified by AMCA. Units to be cULus listed.

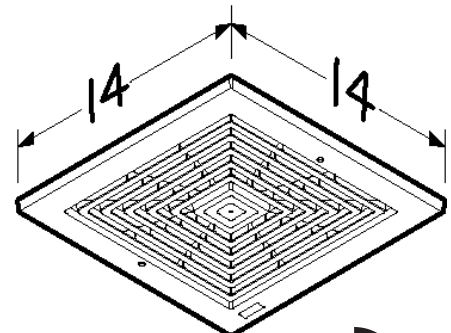
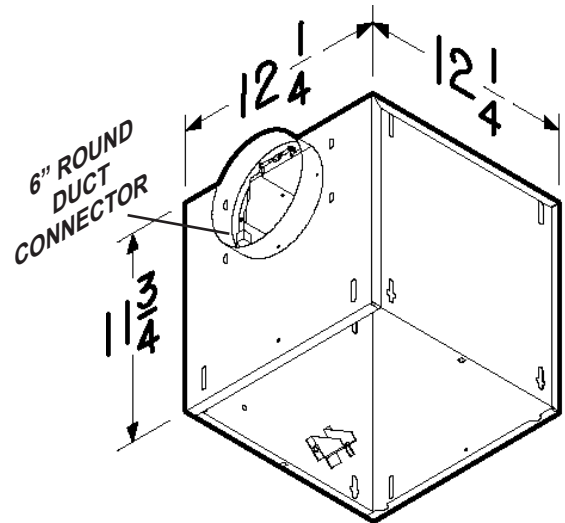

Breidert Air Products, div. of Soler & Palau Ventilation Group, certifies that the models shown herein are licensed to bear the AMCA Seal. The ratings shown are based on tests and procedures performed in accordance with AMCA Publication 211 (and AMCA Publication 311 if sound is also certified) and comply with the requirements of the AMCA Certified Ratings Program.



cULus listed for use over bathtubs and showers when connected to a GFCI-protected branch circuit.

WEIGHT

MODEL NO.	SHIPPING WT.
FF100	22.8 lbs.
FF150	23.1 lbs.



PERFORMANCE RATINGS - CEILING MOUNT VENTILATORS FF100 & FF150

AMCA LICENSED PERFORMANCE RATINGS

MODEL NO.	NOMINAL VOLTAGE	CFM/SONES - AT STATIC PRESSURES (Ps - inches of H ₂ O)										NOMINAL RPM	AMPS @ 60 Hz	WATTS	
		0.0"	.10"	.125"	.250"	.375"	.50"	.625"	.750"	.875"	1.0"				
		Ps	Ps	Ps	Ps	Ps	Ps	Ps	Ps	Ps	Ps				
FF100	120 VAC	CFM Hor.	136	115	109	93	80	65	44	-	-	-	640	1.1	87
		SONES Hor.	0.5	0.8	0.9	1.3	1.8	2.3	3.0	-	-	-			
		CFM Ver.	138	117	112	94	80	67	46	13	-	-	650	1.1	87
		SONES Ver.	0.7	0.9	1.0	1.3	1.8	2.2	2.8	3.0	-	-			
FF150	120 VAC	CFM Hor.	181	161	157	141	132	124	114	94	62	-	710	1.3	100
		SONES Hor.	1.3	1.4	1.5	2.2	2.6	3.1	3.6	4.1	4.6	-			
		CFM Ver.	179	163	160	149	142	133	122	105	73	23	750	1.3	100
		SONES Ver.	1.4	1.6	1.6	2.0	2.5	3.0	3.3	3.6	3.9	4.2			

Performance ratings include the effects of inlet grill and backdraft damper in the airstream. Speed (RPM) shown is nominal. Performance is based on actual speed of test. The sound ratings shown are loudness values in fan sones at 5' (1.5m) in a hemispherical free field calculated per AMCA Std. 301. Values shown are for Installation Type B: free inlet fan sone levels. Performance shown is for Installation Type B: Free inlet, Ducted outlet.



Breidert Air Products, div. of Soler & Palau Ventilation Group, certifies that the models shown herein are licensed to bear the AMCA Seal. The ratings shown are based on tests and procedures performed in accordance with AMCA Publication 211 (and AMCA Publication 311 if sound is also certified) and comply with the requirements of the AMCA Certified Ratings Program.



UL listed for use over bathtubs and showers when connected to a GFCI-protected branch circuit.

