



HRRD-1 DEHUMIDISTAT OPTION FOR HR SERIES

6393 Powers Avenue
Jacksonville, Florida 32217-2298
P: 800.961.7370 F: 800.961.7379
www.solerpalau-usa.com



The HRRD-1 allows the homeowner to select the humidity percentage

Features

- Dehumidistat to select the humidity level
- Compatible with the HR100V, HR160H and HR220H

Electrical Diagram (See figure 3.0)

Electrical Diagram

Figure 3.0

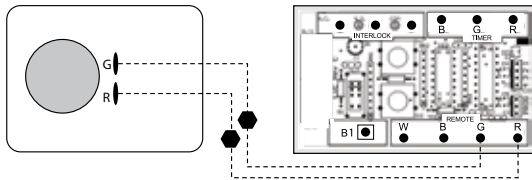

WARNING: Always unplug the unit before installation

Dimensions

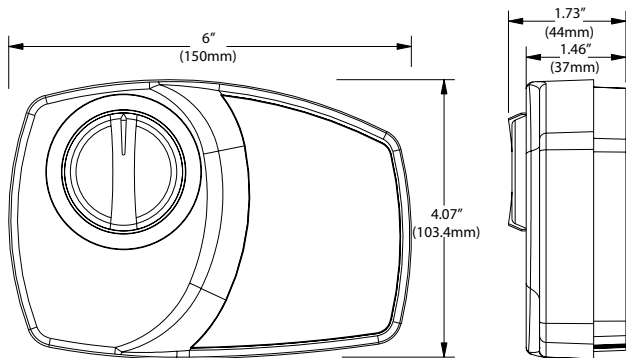

For more information contact us at www.solerpalau-usa.com or 1.800.961.7370 for additional submittal drawings.

S&P will not be responsible for fabrication changes or errors resulting from customer use of a non-current submittal drawing.

PROJECT: _____ CONTRACTOR: _____
 LOCATION: _____ REVISION DATE: _____
 FORM NO.: _____ SUBMITTED BY: _____ DATE: _____
 ENGINEER: _____ APPROVED BY: _____ DATE: _____