

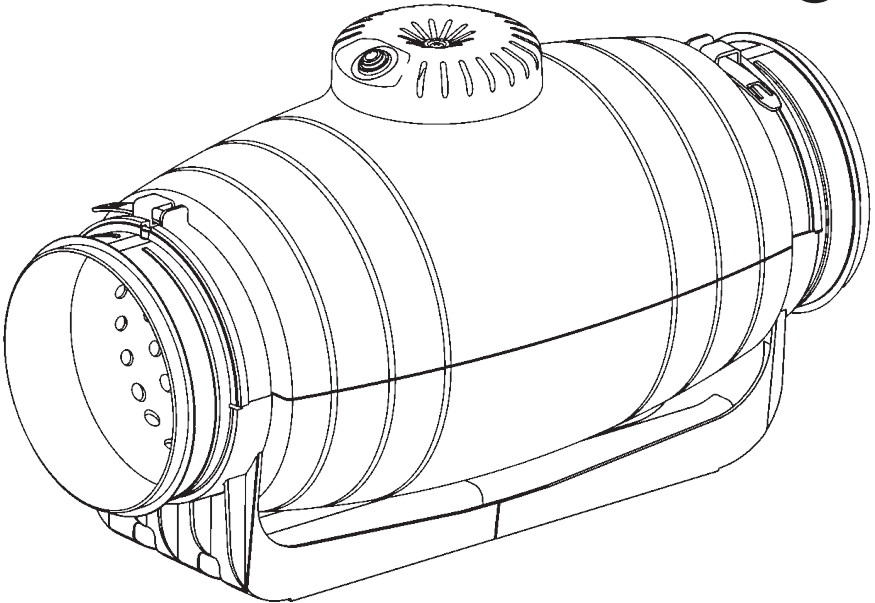

TD-SILENT SERIES (TD)

MIXED FLOW IN LINE DUCT EXHAUST FANS

Models TD-125XS, TD-150S, TD-200S



READ AND SAVE THESE INSTRUCTIONS

The purpose of this manual is to aid in the proper installation and operation of fans manufactured by S&P. These instructions are intended to supplement good general practices and are not intended to cover detailed instruction procedures, because of the wide variety and types of fans manufactured by S&P.

Installation Instructions

TD-SILENT

1. WARNINGS

READ AND SAVE THESE INSTRUCTIONS. FAILURE TO COMPLY WITH INSTRUCTIONS COULD RESULT IN PERSONAL INJURY AND/OR PROPERTY DAMAGE!



CAUTION:

- (1) For General Ventilating Use Only. Do Not Use To Exhaust Hazardous Or Explosive Materials And Vapors.
- (2) The TD-SILENT is suitable for operation within indoor environments only.

WARNING: TO REDUCE THE RISK OF FIRE, ELECTRIC SHOCK OR INJURY, OBSERVE THE FOLLOWING:

1. Use this unit only in the manner intended by the manufacturer. If you have questions, contact the manufacturer.
2. Before servicing or cleaning unit, switch power off at service panel and lock the service disconnecting means to prevent power from being switched on accidentally. When the service disconnecting means cannot be locked, securely fasten a prominent warning device, such as a tag, to the service panel.
3. Installation work and electrical wiring must be done by qualified person(s) in accordance with all applicable codes and standards, including fire-rated construction.
4. Sufficient air is needed for proper combustion and exhausting of gases through the flue (chimney) of fuel burning equipment to prevent back drafting. Follow the heating equipment manufacturer's guideline and safety standards such as those published by the National Fire Protection Association (NFPA), and the American Society for Heating, Refrigeration and Air Conditioning Engineers (ASHRAE), and the local code authorities.
5. When cutting or drilling into wall or ceiling, do not damage electrical wiring and other hidden utilities.
6. Ducted fans must always be vented to the outdoors.
7. If this unit is to be installed over a tub or a shower, it must be marked as appropriate for the application and connected to a GFCI (Ground Fault Circuit Interrupter) - protected branch circuit.
8. Never place a switch where it can be reached from a tub or shower.
9. CAUTION: MOUNT WITH THE LOWEST MOVING PARTS AT LEAST 2.4 M (8 FEET) ABOVE THE FLOOR OR GRADE LEVEL.
10. All the units are suitable for use with solid state speed control

2. PRE-INSTALLATION INSPECTION

The TD-SILENT mixed flow range of in-line duct exhaust fans have been manufactured in accordance with the rigorous standards of production as defined by the International Quality Standards ISO 9001. All the components have been checked and tested at the end of the manufacturing process.

We recommend that you check the following after receiving this product:

1. The correct size has been received
2. The correct model has been received
3. The details on the rating label correspond to the electrical supply: voltage, frequency etc.

Remove the unit from packaging and inspect for shipping damage within 15 days of receipt. If the product is found to be damaged, immediately contact your local authorized supplier. **DO NOT OPERATE THE UNIT IF DAMAGED.** These instructions should be considered as a supplement to EPA standard practices, as well as all state and local building code regulations.

Before installing the product check the following points:

1. The damper blade opens and closes freely.
2. There are no obstructions to the airflow.

3. ENVIRONMENT

The TD-SILENT series of fans are suitable for operation within indoor environments only. The TD-SILENT units are suitable for the exhaust or supply of both conditioned and unconditioned airstreams within the temperature ranges. Size 125XS and 200S are suitable for working airstreams up to 104 deg F (40C), whereas sizes 150S is suitable for working airstreams up to 140 deg F (60C).



4. MOUNTING

The TD-SILENT series can be mounted in any orientation, horizontal or vertical, and is suitable for numerous types of applications. See Figure (1). Illustration of some typical applications. If the installation is made to rigid or flexible ducting, then we would recommend the correct diameter ducting is used to couple to the fan flanges. If it is necessary to bend the duct at the discharge of the fan, then the bend radius should be as large as possible.

All models include a robust mounting bracket which enables easy and quick installation of the fan. See Figure (2) Installation Diagrams For TD-MIXVENT Duct Fans.

Seal penetrations, duct, and fan with duct fast clamps, duct tape, or other similar material (available through your local distributor) to create an air-tight path from the ventilated space to the building exterior.

Use flexible or rigid insulated duct and wrap the fan with insulation where allowed by code in order to reduce: heard noise, building heat loss/gain, and condensation.

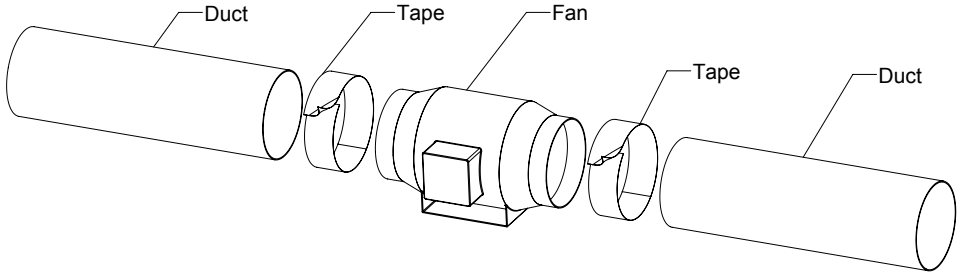

The ducting from this fan to the outside of the building has a strong effect on the air flow, noise, and energy use of the fan. Use the shortest, straightest duct routing possible for the best performance, and avoid installing the fan with smaller ducts than recommended. Insulation around the ducts can reduce energy loss and inhibit mold growth. Fans installed with existing ducts may not achieve their rated flow.

Model	Recommended Round Duct Size (in.)
TD-125XS	5"
TD-150S	6"
TD-200S	8"

To ensure quiet operation of ENERGY STAR® qualified inline and remote fans, each fan shall be installed using sound attenuation techniques appropriate for the installation. For bathroom and general ventilation applications, at least 8 feet of insulated flexible duct shall be installed between the exhaust or supply grille(s) and the fan. For remote ventilation applications, where metal duct is generally required by code, a metal sound attenuator shall be installed between the hood and the fan.

5. ELECTRICAL CONNECTION

All TD-SILENT series fans operate from a standard 120V, 60Hz AC electrical supply. All wiring must be carried out in accordance with National Electrical Code and all applicable state and local buildings codes.

Electrical connections should be made in accordance with the following diagram: See Figure (3)

6. MAINTENANCE

IMPORTANT: BEFORE CARRYING OUT ANY MAINTENANCE OR SERVICING, ENSURE THE UNIT IS DISCONNECTED FROM THE MAIN ELECTRICAL SUPPLY.



All TD-SILENT series exhaust fans incorporate sealed for life bearings and therefore do not require any lubrication. We would recommend inspection of the product at least once every twelve (12) months to avoid the excessive accumulation of dust and dirt on the impeller. To inspect the unit disconnect from electrical supply and remove from ducting. If any debris is evident on the impeller clean with a damp (not wet) cloth. DO NOT USE any detergents or abrasive materials for cleaning.

Figure 1. Typical Applications

• Single Point Exhaust System

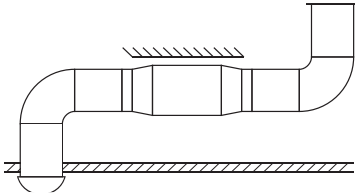

Note:

- Seal joints with tape
- Use round elbows

• Multi-Point Exhaust System

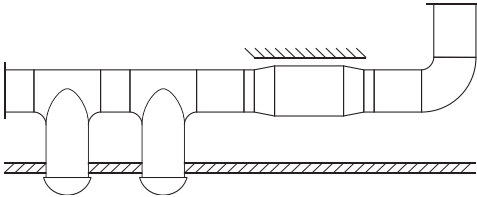

Note:

- Seal joints with tape
- Use round elbows

Figure 2. Installing TD-SILENT SERIES.

Models TD-125XS, TD-150S and TD-200S

1. To install the TD-SILENT models the fan motor, wheel assembly must first be removed
Unlock the two flanges around the casing and remove.
2. Secure the mounting bracket, fan flange assembly to a fixed structure.
3. Replace the fan motor, wheel assembly and tighten the two flanges to secure the product.

Figure 3. Electrical Wiring

1. Motor without Speed Controller.

Note: Models TD-125XS, TD-150S and TD-200S are double insulated and are not provided with external ground wire.



2. Motor with Speed Controller

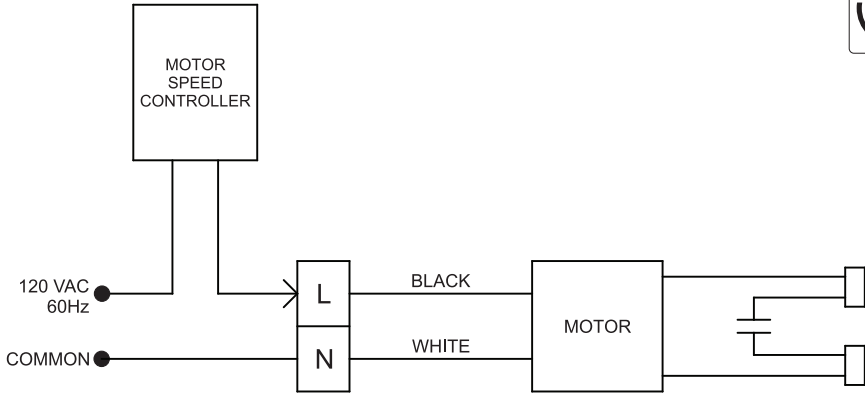

7. WARRANTY

S&P USA - S&P Canada warrant that the eGED/eGSD will be free from defective materials and workmanship for the period of (5) years from the date of original purchase. In the event that we find any part is defective the product will be repaired or, in the Company's discretion, replaced without charge provided that the product has been installed in accordance with the enclosed instructions and all applicable EPA Standards and state and local building codes.

IF CLAIMING UNDER WARRANTY: Please return the complete product, freight paid, to your local authorized distributor. All returns must be accompanied by a valid Bill Of Sale. All returns must be clearly marked "Warranty Claim," with an accompanying description stating the nature of the fault. THE FOLLOWING WARRANTIES DO NOT APPLY: Damages from shipping, either concealed or visible. Claim must be filed with the carrier. Damages resulting from improper wiring or installation Damages caused by acts of nature, or resulting from improper consumer procedures such as: Improper Maintenance; Misuse; Negligence; Alteration; Abuse; Abnormal Use; or Accident or Incorrect Electrical Voltage and Current. Removal or alteration to the S&P USA - S&P Canada data plate label.

WARRANTY VALIDATION: The end user must keep a copy of the Bill of Sale to verify purchase date.

THE ABOVE (5) YEAR WARRANTY IS EXPRESSLY IN LIEU OF ALL OTHER WARRANTIES, EXPRESSED, WRITTEN OR IMPLIED, INCLUDING THE WARRANTIES OF MERCHANTABILITY AND FITNESS FOR USE. IN NO EVENT SHALL Soler & Palau USA - Soler & Palau CANADA BE LIABLE FOR ANY SPECIAL, CONSEQUENTIAL, OR INCIDENTAL DAMAGES, INCLUDING LOSS OF PROPERTY, REVENUES, LOST PROFITS, COSTS OF REMOVAL, INSTALLATION OR REINSTALLATION.

LIMITATION OF WARRANTY AND LIABILITY:

This warranty does not apply to any such S&P product or parts which have failed as a result of faulty installation or abuse, or incorrect electrical connections or alterations, made by others, or use under abnormal operating conditions or misapplication of the products and parts.

Soler & Palau USA will not approve for payment any repairs made outside the factory without prior written consent of its Jacksonville, Florida office.

The foregoing shall constitute our sole and exclusive warranty and our sole and exclusive liability and is in lieu of all other warranties, whether written, oral, implied or statutory. There are no warranties which extend beyond the description of the page hereof. Seller does not warrant that said goods and articles are of merchantable quality or that they are fit for any particular purpose. The liability of seller on any claim of any kind, including negligence, for any loss or damage arising out of or connected with, or resulting from the sale and purchase of the products and parts covered by this proposal, acknowledgement, order or from the performance or breach of any contract pertaining to such sale or purchase, or from the design, manufacture, sale, delivery, resale, installation, technical direction of installation, inspection, repair, operation or use of any products or parts covered by this proposal, acknowledgement, order or furnished by seller shall, in no case exceed the price allocable to the products or parts thereof which give rise to the claim and shall terminate one (1) year after the shipment of said products and parts.

In no event, whether as a result of breach of contract, or warranty or alleged negligence, defects, incorrect advice or other causes, shall seller be liable for special or consequential damages, including, but not limited to, loss of profits or revenue, loss of use of the equipment or any associated equipment, cost of capital, cost of substitute equipment, facilities or services, down time costs, or claims of customers of the purchaser for such damages. Soler & Palau USA neither assumes nor authorizes any persons to assume for it any other liability in connection with the sale of its fan products and parts. Some states do not allow the exclusion or limitation of incidental or consequential damages, so all of the above limitations or exclusions may not apply to you.

SAFETY ACCESSORIES WARNING:

The responsibility for providing safety accessories for equipment supplied by Soler & Palau USA is that of the installer and user of this equipment. Soler & Palau USA sells its equipment with and without safety accessories, and accordingly it can supply such safety accessories upon receipt of order.

The user, in making its determination as to the appropriate safety accessories to be installed and any warning notices, should consider (1) the location of the installation, (2) the accessibility of employees and other persons to this equipment, (3) any adjacent equipment, (4) applicable building codes, and (5) requirements of the Federal Occupational Safety and Health Act. Users and installers of this equipment should read "RECOMMENDED SAFETY PRACTICES FOR AIR MOVING DEVICES" which is published by Air Movement and Control Association, 30 West University Drive, Arlington Heights, Illinois 60004.



S&P USA Ventilation Systems, LLC

6393 Powers Avenue
Jacksonville, FL 32217
T. 904-731-4711 • F. 904-737-8322
www.solerpalau-usa.com

S&P Canada Ventilation Products, Inc.

6710 Maritz Drive Unit #7
Mississauga, ON L5W 0A1 - Canada
T. 416-744-1217 • F. 416-744-0887
www.solerpalaucanada.com

