

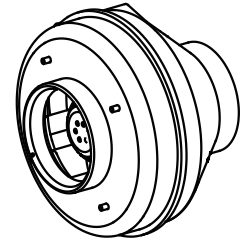

Radon Mitigation Fan



MODEL: PRF-100 PRF-150

WARNING

TO REDUCE THE RISK OF FIRE, ELECTRIC SHOCK, OR INJURY TO PERSONS, OBSERVE THE FOLLOWING:

1. Use this unit only in the manner intended by the manufacturer. If you have questions, contact the manufacturer.
2. Before servicing or cleaning unit, switch power off at service panel and lock the service disconnecting means to prevent power from being switching on accidentally. When the service disconnecting means cannot be locked, securely fasten a prominent warning device, such as a tag, to the service panel.
3. Installation work and electrical wiring must be done by a qualified person(s) in accordance with all applicable codes and standards, including fire-rated construction codes and standards.
4. Sufficient air is needed for proper combustion and exhausting of gases through the flue (chimney) of fuel burning equipment to prevent backdrafting. Follow the heating equipment manufacturer's guideline and safety standards such as those published by the National Fire Protection Association (NFPA), and the American Society for Heating, Refrigeration and Air Conditioning Engineers (ASHRAE), and the local code authorities.
5. When cutting or drilling into wall or ceiling, do not damage electrical wiring and other hidden utilities.
6. Ducted fans must always be vented to the outdoors.
7. Acceptable for use over a tub or shower when connected to a GFCI (Ground Fault Circuit Interrupter) - protected branch circuit .
8. This unit must be grounded.
9. To reduce risk of fire and to properly exhaust air, be sure to duct air outside – Do not vent exhaust air into spaces within walls or ceilings or into attics, crawl spaces, or garages.
10. NEVER place a switch where it can be reached from a tub or shower.
11. Do not install this fan where the temperature may exceed 60 degrees Celsius (140 degrees Fahrenheit).

CAUTION

1. For general ventilating use only. Do not use to exhaust hazardous or explosive materials and vapors.
2. To avoid motor bearing damage and noisy and/or unbalanced impellers, keep drywall spray, construction dust, etc. off power unit.
3. Please read specification label on product for further information and requirements.

CLEANING & MAINTENANCE

The motor is permanently lubricated and never needs oiling.

OPERATION

Use an on/off switch to operate this fan. See "WIRING DIAGRAM" for details.

INSTALLATION

The Fan may be mounted indoors or outdoors.
The fan may be mounted directly on the system duct or mounted with mounting bracket.

OUTDOOR INSTALLATION

When mounting directly on the system duct assure that the fan does not contact any building surface to avoid vibration noise. Mount the fan vertically with outlet up.

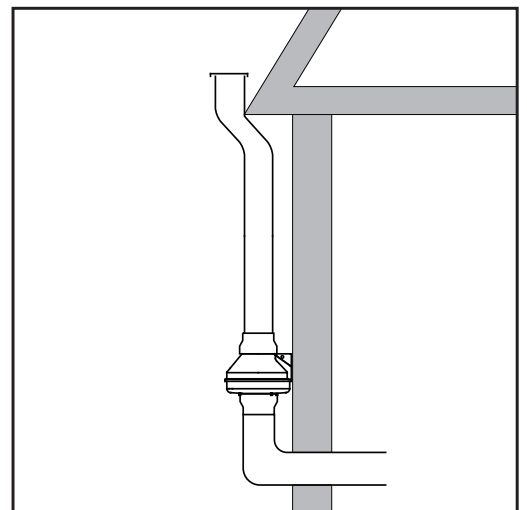

READ AND SAVE THESE INSTRUCTIONS

Installer: Leave this manual with the homeowner.

Cod: 0060301412

INSTALLATION

INDOOR INSTALLATION

Select the location for fan mounting which minimizes noise generated by fan operation, and allows sufficient access for installation and maintenance. Secure the mounting bracket to the support beam with screws.

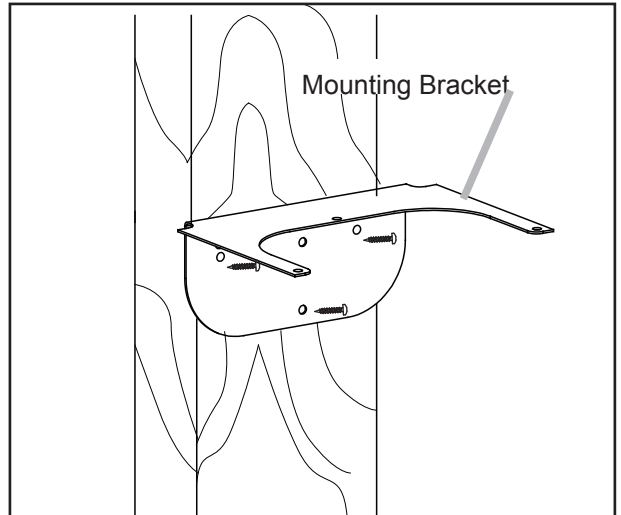

Insert the studs into the holes of the mounting bracket. Secure the fan to the mounting bracket with self-tapping screws. The position of the junction box should be convenient for wiring.

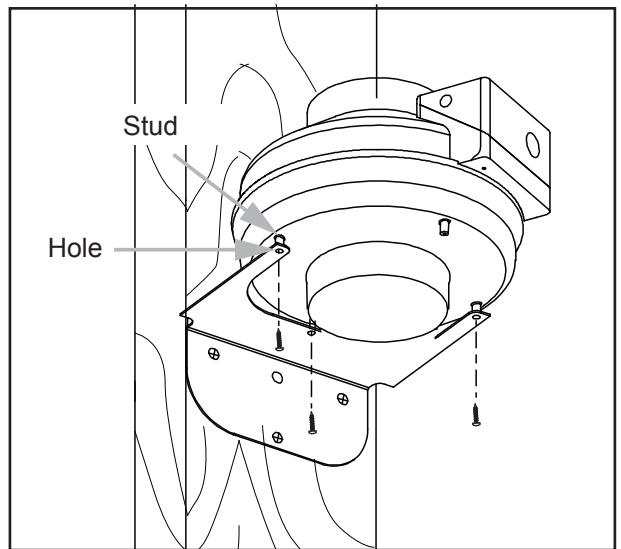

Connect the ductwork. Use duct tape to secure all of the ductwork connections so that they are air tight. A backdraft damper installed at the outlet is highly recommended to prevent cold air from entering the dwelling.

Note: Install with enough clearance (1/4") between the coupling and the top of the junction box to enable accessibility.

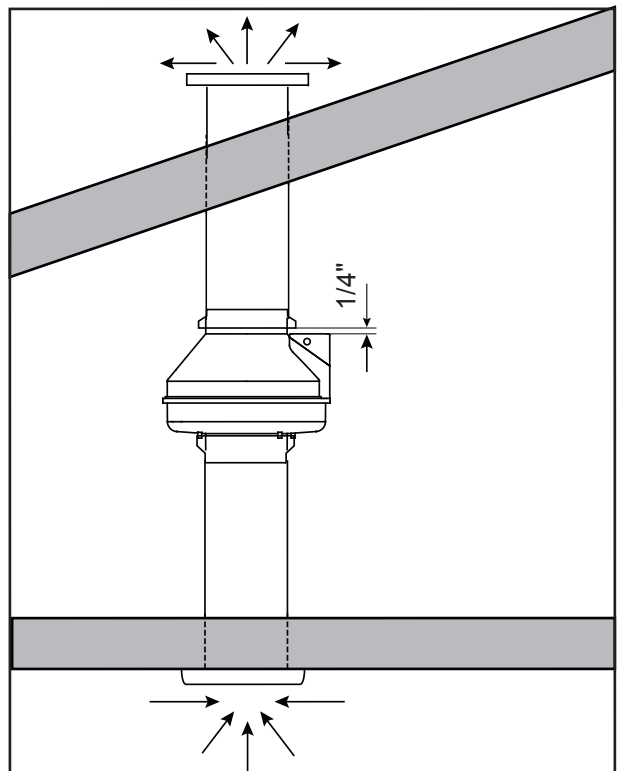

INSTALLATION

Remove junction box cover. Wire per Wiring Diagram below. Replace the fan junction box cover use screws.

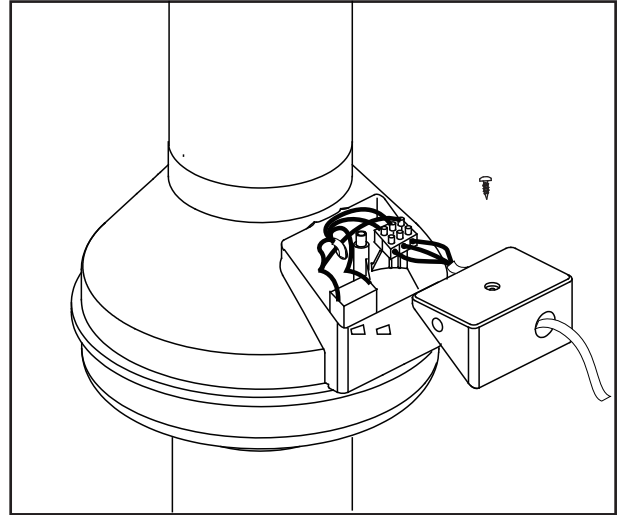

WIRING DIAGRAM

Run 120V AC house wiring to the location of the fan. Refer to the wiring diagram below, and connect the wires as shown.

PRF-100

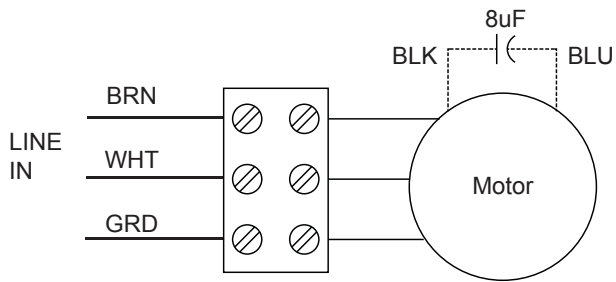

PRF-150

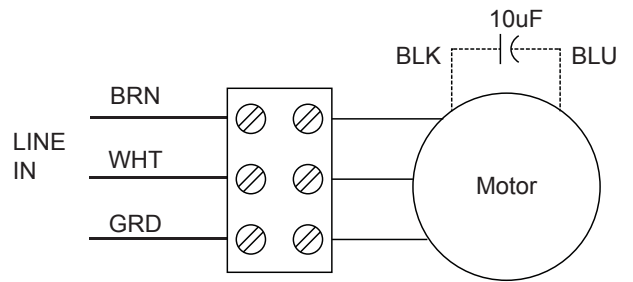

SERVICE PARTS

PART	PART NAME	Qty.
1	Motor capacitor	1
2	Terminal block	1
3	Screw	4
4	Junction box cover	1
5	Screw	1

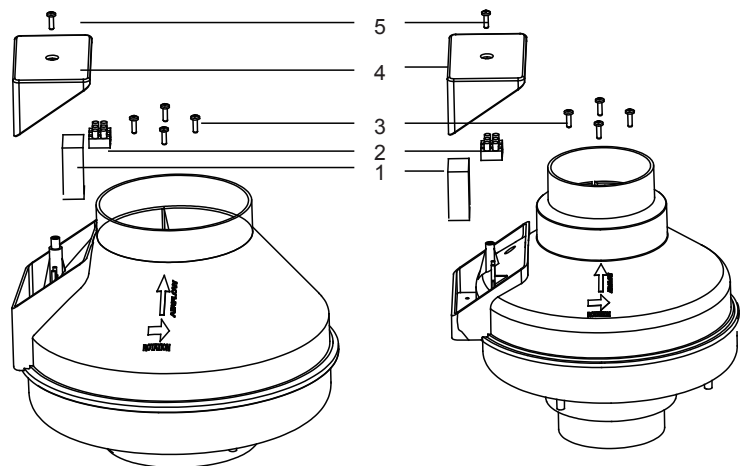

PRF-150

PRF-100

WARRANTY

S&P USA Ventilation Systems, LLC. & S&P Canada Ventilation Products, Inc. warrants to the original end user of its products that our exhaust fans will be free from defects in materials and workmanship for a period of Five (5) years from the date of original purchase. THERE ARE NO OTHER WARRANTIES, EXPRESSED OR IMPLIED, INCLUDING BUT NOT LIMITED TO IMPLIED WARRANTIES OF SUITABILITY FOR A PARTICULAR PURPOSE.

During this five year period, S&P will, at its option, repair returned products or parts, or provide replacement products or parts, without charge, for any product or part which is found to be defective under normal use.

This warranty does not cover normal maintenance and service or any parts that have been subject to misuse, negligence, accident, improper maintenance or repair, faulty installation or installation contrary to recommended installation instructions.

S&P's obligation to repair or replace, at S&P's option, shall be the purchaser's sole and exclusive remedy under this warranty. No labor or materials are covered by this warranty. S&P shall not be liable for incidental damages arising out of or in connection with product use or performance.

This warranty gives you specific legal rights. You may also have other rights which vary from state to state.

To qualify for warranty service, you must notify S&P at the address or telephone number stated below, provide the model number and part identification, and describe the nature of any defect in product or part. You may be required to ship a defective part to S&P. There will be no charge for shipping repaired or replacement parts from S&P to you if your address is in the United States or Canada. At the time of requesting warranty service, you must present evidence of the original purchase date.

S&P USA Ventilation Systems, LLC.
6393 Powers Avenue Jacksonville, FL 32217
P. 904-731-4711
F. 904-731-8322
www.spvg-northamerica.com

S&P Canada Ventilation Products, Inc.
5600 Ambler Drive Mississauga, ON L4W 2K9
P. 866-733-0233
F. 866-358-5346
www.solerpalaucanada.com