

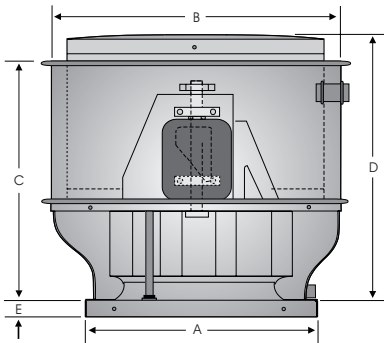

P: 800.961.7370
www.solerpalau-usa.com

MODEL TXB BELT DRIVE CENTRIFUGAL UPBLAST ROOF EXHAUSTER

SIZE	DIMENSIONS (IN.)							AVG. SHIP WT. (LBS)
	A	B	C	D	E	F	G	
8	16 1/2	24	24	27	1 3/4	11 3/4	14 3/4	69
10	16 1/2	27	26	29	1 3/4	11 3/4	14 3/4	69
12/15/16	24	31 1/2	26	29	2 1/2	19 1/4	22 1/4	93
18/20	29 1/2	37 3/4	28 1/2	32	2 1/2	24 3/4	27 3/4	120
24	35 1/2	47 1/4	31 1/2	42	2 1/2	30 3/4	33 3/4	245
30	42 1/2	56 3/4	41	45	2 1/2	37 3/4	40 3/4	365
36	42 1/2	66	44	48	2 1/2	37 3/4	40 3/4	365
42	55	72 1/2	48	52	2 1/2	50 1/4	53 1/4	385
48	55	78 3/4	52	56	2 1/2	50 1/4	53 1/4	490



- A - Inside dimension of square curb cap.
- B - Outside diameter of unit.
- C - Height of exhaust opening above curb cap.
- D - Height of unit above top of curb.
- E - Depth of curb mounting flange.
- F - Recommended roof opening.
- (Inside dimension of factory built prefab curb).
- G - Outside dimension of factory built prefab curb.

SIZE	METAL GAUGES				
	WIND BAND	MOTOR COVER	SHROUD	BASE	
				STD/UL	RHUL
8/10	.050	.050	.063	.063	16GA
12/15/16	.050	.050	.063	.063	16GA
18/20	.050	.050	.080	.080	16GA
24	.050	.050	.100	.080	16GA
30	.050	.050	.100	.090	16GA
36	.050	.050	.090	.090	16GA
42	.050	.050	.090	.100	N/A
48	.050	.050	.090	.100	N/A



cULus 705
cULus 762 (Grease)

FAN SPECIFICATIONS									MOTOR SPECIFICATIONS				
Line	Qty.	Model No.	Tag	CFM	SP	Fan RPM	BHP	Sones	HP	Volts	Phase	Hertz	Encl
1													
2													
3													
4													
5													

ACCESSORY ITEMS	1	2	3	4	5	ACCESSORY ITEMS	1	2	3	4	5
<input type="checkbox"/>						<input type="checkbox"/>					
<input type="checkbox"/>						<input type="checkbox"/>					
<input type="checkbox"/>						<input type="checkbox"/>					
<input type="checkbox"/>						<input type="checkbox"/>					
<input type="checkbox"/>						<input type="checkbox"/>					

Project: _____ Submitted: _____
 Customer: _____ Approved: _____
 Location: _____



P: 800.961.7370
www.solerpalau-usa.com

MODEL TXB-RHUL UL762 LISTED RESTAURANT BELT DRIVE CENTRIFUGAL UPBLAST ROOF EXHAUSTER

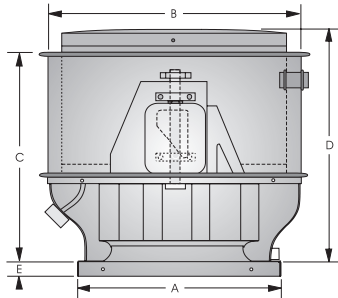

SIZE	DIMENSIONS (IN.)							AVG. SHIP WT. (LBS)
	A	B	C	D	E	F	G	
8	16 1/2	24	24	27	1 3/4	11 3/4	14 3/4	69
10	16 1/2	27	26	29	1 3/4	11 3/4	14 3/4	69
12/15/16	24	31 1/2	26	29	2 1/2	19 1/4	22 1/4	93
18/20	29 1/2	37 3/4	28 1/2	32	2 1/2	24 3/4	27 3/4	120
24	35 1/2	47 1/4	31 1/2	42	2 1/2	30 3/4	33 3/4	245
30	42 1/2	56 3/4	41	45	2 1/2	37 3/4	40 3/4	365
36	42 1/2	66	44	48	2 1/2	37 3/4	40 3/4	365
42	55	72 1/2	48	52	2 1/2	50 1/4	53 1/4	385
48	55	78 3/4	52	56	2 1/2	50 1/4	53 1/4	490

A - Inside dimension of square curb cap.
B - Outside diameter of unit.
C - Height of exhaust opening above curb cap.
D - Height of unit above top of curb.
E - Depth of curb mounting flange.
F - Recommended roof opening.
G - Outside dimension of factory built prefab curb.
(Inside dimension of factory built prefab curb.)



OPTIONAL
(Must be specified)

cULus 705
cULus 762 (Grease)

SIZE	METAL GAUGES				
	WIND BAND	MOTOR COVER	SHROUD	BASE	
				STD/UL	RHUL
8/10	.050	.050	.063	.063	16GA
12/15/16	.050	.050	.063	.063	16GA
18/20	.050	.050	.080	.080	16GA
24	.050	.050	.100	.080	16GA
30	.050	.050	.100	.090	16GA
36	.050	.050	.090	.090	16GA
42	.050	.050	.090	.100	N/A
48	.050	.050	.090	.100	N/A

FAN FEATURES

- AMCA Air and Sound Licensed
- UL 705 listed
- UL 762 listed for Grease Removal
- Rainproof Electrical Box with Wiring Chase
- Heavy-Gauge Aluminum Construction
- Nonoverloading Aluminum Backward Inclined Wheel
- Drives Sized for a Minimum of 150% of Motor Horsepower
- 1 Year Fan and Motor Warranty
- Heavy-Duty 200,000 Hour Rated Pillow Block Bearings
- Single Piece Deep Spun Inlet with Welded Corners

FAN SPECIFICATIONS									MOTOR SPECIFICATIONS				
Line	Qty.	Model No.	Tag	CFM	SP	Fan RPM	BHP	Sones	HP	Volts	Phase	Hertz	Encl
1													
2													
3													
4													
5													

ACCESSORY ITEMS	1	2	3	4	5	ACCESSORY ITEMS	1	2	3	4	5
<input type="checkbox"/>						<input type="checkbox"/>					
<input type="checkbox"/>						<input type="checkbox"/>					
<input type="checkbox"/>						<input type="checkbox"/>					
<input type="checkbox"/>						<input type="checkbox"/>					
<input type="checkbox"/>						<input type="checkbox"/>					

Project: _____ Submitted: _____
 Customer: _____ Approved: _____
 Location: _____



MODEL TXBW BELT DRIVE CENTRIFUGAL SIDEWALL MOUNT EXHAUSTER



cULus 705
cULus 762 (Grease)

OPTIONAL
(Must be specified)

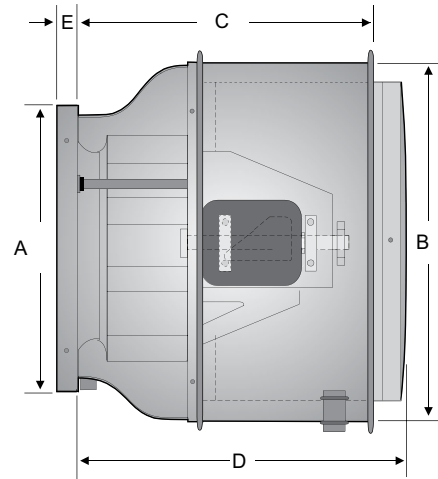

SIZE	DIMENSIONS (IN.)						AVG. SHIP WT. (LBS)	METAL GAUGES				
	A	B	C	D	E	F		WIND BAND	MOTOR COVER	SHROUD	BASE	
											STD/UL	RHUL
8	16-1/2	24	24	27	1-3/4	11-3/4	69	.050	.050	.063	.063	16GA
10	16-1/2	27	26	29	1-3/4	11-3/4	69	.050	.050	.063	.063	16GA
12/15/16	24	31-1/2	26	29	2-1/2	19-1/4	93	.050	.050	.063	.063	16GA
18/20	29-1/2	37-3/4	28	32	2-1/2	24-3/4	120	.050	.050	.063	.080	16GA
24	35-1/2	47-1/4	33-1/2	41	2-1/2	30-3/4	245	.050	.050	.100	.080	16GA

A - Inside dimension of fan base.
B - Outside diameter of windband.
C - Length of shroud and windband.

D - Length of fan with motor cover.
E - Depth of mounting flange.
F - Recommended wall opening.

NOTE: Unit comes with disconnect and birdscreen.
UL 762 grease unit does not have birdscreen.

FAN SPECIFICATIONS									MOTOR SPECIFICATIONS				
Line	Qty.	Model No.	Tag	CFM	SP	Fan RPM	BHP	Sones	HP	Volts	Phase	Hertz	Encl
1													
2													
3													
4													
5													

ACCESSORY ITEMS	1	2	3	4	5	ACCESSORY ITEMS	1	2	3	4	5
<input type="checkbox"/>						<input type="checkbox"/>					
<input type="checkbox"/>						<input type="checkbox"/>					
<input type="checkbox"/>						<input type="checkbox"/>					
<input type="checkbox"/>						<input type="checkbox"/>					
<input type="checkbox"/>						<input type="checkbox"/>					

Project: _____ Submitted: _____
 Customer: _____ Approved: _____
 Location: _____

Subject to change unless approved in submittal by S&P

