

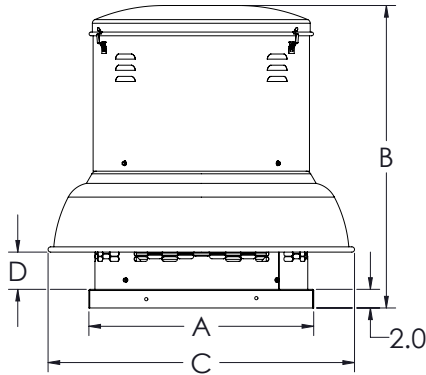

MODEL SDB BELT DRIVE CENTRIFUGAL DOWNBLAST ROOF EXHAUSTER



STANDARD FEATURES

- Exhaust air up to 4135 CFM in high static pressure applications up to 1-1/2" w.g.
- Attractive spun aluminum exterior
- Belt drives permit easy performance adjustments when needed
- Curved non-overloading backward inclined wheel for efficiency at higher static pressures
- AMCA Air and Sound Licensed
- cULus 705 Listed



Size	A	B	C	D	Roof Opening	Curb O.D.	Damper (O.D.)	Average Ship Wt. Lbs.
6	18 1/8	30 1/16	25	3 3/8	13 1/2	16 1/2	12	109
7	18 1/8	30 1/16	25	3 3/8	13 1/2	16 1/2	12	109
8	18 1/8	30 1/16	25	3 3/8	13 1/2	16 1/2	12	109
10	18 1/8	30 1/16	25	3 3/8	13 1/2	16 1/2	12	109
12	20 1/8	31 11/16	27 9/16	3 7/8	15 1/2	18 1/2	14	122
14	20 1/8	31 11/16	27 9/16	3 7/8	15 1/2	18 1/2	14	126
15	24 1/8	32 7/16	32 7/8	4	19 1/2	22 1/2	18	140
16	24 1/8	32 7/16	32 7/8	4	19 1/2	22 1/2	18	140

NOTE: All dimensions shown are in inches.

FAN SPECIFICATIONS									MOTOR SPECIFICATIONS				
Line	Qty.	Model No.	Tag	CFM	SP	Fan RPM	BHP	Sones	HP	Volts	Phase	Hertz	Encl
1													
2													
3													
4													
5													

ACCESSORY ITEMS	1	2	3	4	5	ACCESSORY ITEMS	1	2	3	4	5
<input type="checkbox"/>						<input type="checkbox"/>					
<input type="checkbox"/>						<input type="checkbox"/>					
<input type="checkbox"/>						<input type="checkbox"/>					
<input type="checkbox"/>						<input type="checkbox"/>					
<input type="checkbox"/>						<input type="checkbox"/>					

Subject to change unless approved in submittal by Soler & Palau
SDB_Submittal