

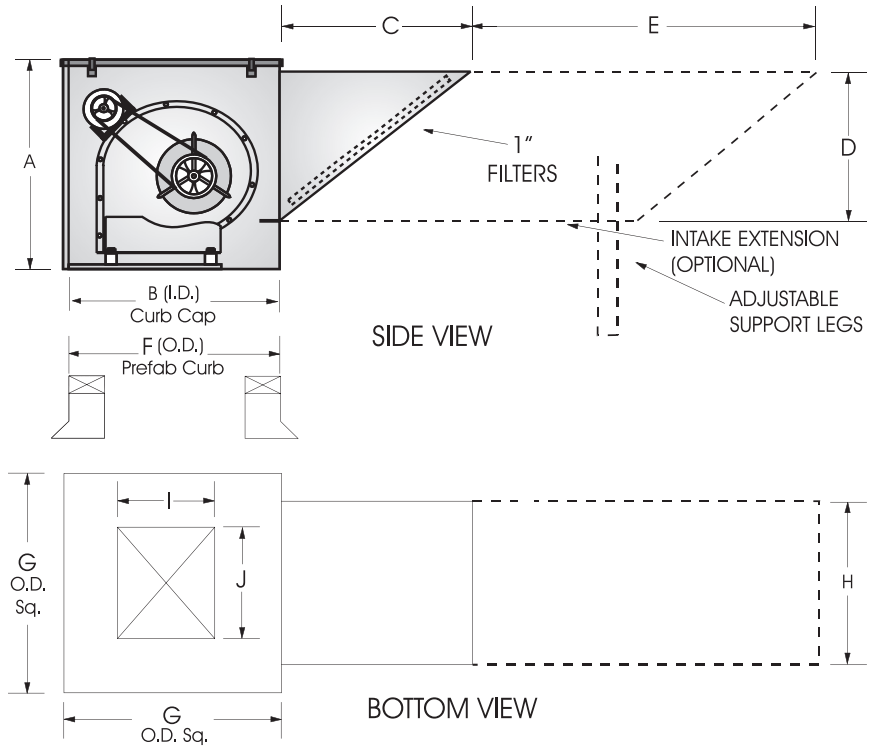

P: 800.961.7370
www.solerpalau-usa.com



MODEL KSF KITCHEN SUPPLY FAN



| SIZE | A | B SQ. | C | D | E | F | G | H | DAMPER O.D. | I | J | FILTERS (QTY) |
|------|--------|--------|--------|--------|--------|--------|--------|--------|-------------|--------|--------|---------------------|
| 9 | 24 1/4 | 24 1/2 | 17 7/8 | 19 | 78 3/4 | 22 3/4 | 24 1/2 | 18 | 19 | 10-1/2 | 12 | 17 1/2 x 23 (1) |
| 10 | 27 3/8 | 28 1/2 | 21 1/8 | 22 1/2 | 70 1/2 | 26 1/2 | 28 1/4 | 21 3/4 | 23 | 11-5/8 | 13-1/4 | 21 1/2 x 28 1/2 (1) |
| 12 | 32 3/4 | 32 1/2 | 26 1/2 | 27 7/8 | 51 1/2 | 30 1/2 | 32 1/2 | 27 1/4 | 27 | 13-5/8 | 15-7/8 | 25 1/2 x 35 1/2 (1) |
| 15 | 37 3/8 | 32 1/2 | 34 1/4 | 30 3/8 | 56 1/2 | 30 1/2 | 32 1/2 | 28 3/4 | 27 | 16-1/4 | 18-7/8 | 21 1/2 x 28 1/2 (2) |
| 18 | 41 3/8 | 36 1/2 | 38 1/4 | 33 3/8 | 48-1/2 | 34-5/8 | 36-1/2 | 31 | 30 | 19 | 22-1/4 | 24 x 30 (2) |
| 20 | 49-1/2 | 51 1/2 | 37 1/2 | 38 3/4 | 31 | 49 | 51 | 46-1/8 | 45 | 23 | 25 | 25 1/2 x 45 1/2 (2) |

| FAN SPECIFICATIONS | | | | | | | | | MOTOR SPECIFICATIONS | | | | |
|--------------------|------|-----------|-----|-----|----|---------|-----|-------|----------------------|-------|-------|-------|------|
| Line | Qty. | Model No. | Tag | CFM | SP | Fan RPM | BHP | Sones | HP | Volts | Phase | Hertz | Encl |
| 1 | | | | | | | | | | | | | |
| 2 | | | | | | | | | | | | | |
| 3 | | | | | | | | | | | | | |
| 4 | | | | | | | | | | | | | |
| 5 | | | | | | | | | | | | | |

| ACCESSORY ITEMS | | | | | ACCESSORY ITEMS | | | | | | |
|--------------------------|---|---|---|---|-----------------|--------------------------|---|---|---|---|---|
| | 1 | 2 | 3 | 4 | 5 | | 1 | 2 | 3 | 4 | 5 |
| <input type="checkbox"/> | | | | | | <input type="checkbox"/> | | | | | |
| <input type="checkbox"/> | | | | | | <input type="checkbox"/> | | | | | |
| <input type="checkbox"/> | | | | | | <input type="checkbox"/> | | | | | |
| <input type="checkbox"/> | | | | | | <input type="checkbox"/> | | | | | |
| <input type="checkbox"/> | | | | | | <input type="checkbox"/> | | | | | |

Subject to change unless approved in submittal by Soler & Palau USA
KSF_Submittal_0407

