

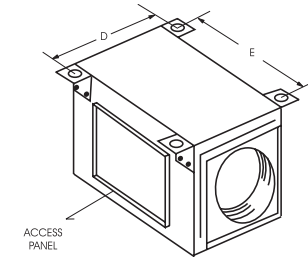

MODEL eSQD SQUARE INLINE DUCT FANS WITH EC MOTORS

STANDARD FEATURES

- Nonoverloading, backwardly inclined wheel.
- Spark resistant wheel on all sizes.
- Safety disconnect standard for all motors except two speed and explosion proof (shipped loose).
- Housing corrosion resistant galvanized steel.
- Heavy-duty internal support structure.
- Integral duct flanges.
- UL 705 label for Electrical Safety & Reliability.

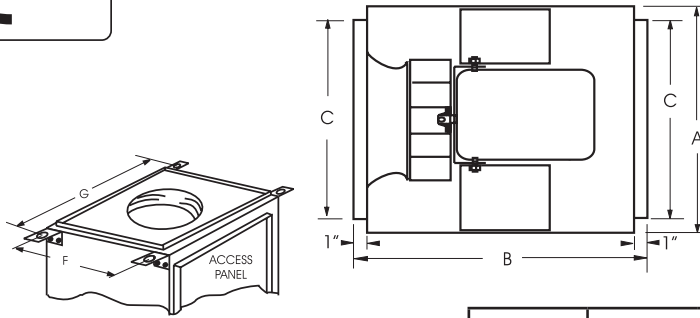

SIZE	STANDARD DIMENSIONS (IN.)						
	A	B	C	D	E	F	G
8	16	17	11 7/8	20 3/4	13	14	19 1/2
10	19	20	13 7/8	23 3/4	16	17	22 1/2
12	23	24	15 7/8	27 3/4	20	21	26 1/2

SIZE	STANDARD MATERIAL & THICKNESS			AVG. SHIP WT. (LBS.)	INLET OR OUTLET AREA
	GALV HOUSING GAUGE	VENTURI INLET	STD WHEEL		
8	18	.063	Alum	60	1.0 Sq Ft
10	18	.063	Alum	75	1.4 Sq Ft
12	18	.063	Alum	90	1.8 Sq Ft

NOTE: Optional Mounting Brackets may be mounted on sides or ends of unit for floor, ceiling or vertical mounting.

(ARRANGE FOR BEST USE OF ACCESS PANELS)



FAN SPECIFICATIONS									MOTOR SPECIFICATIONS				
Line	Qty.	Model No.	Tag	CFM	SP	Fan RPM	BHP	Sones	HP	Volts	Phase	Hertz	Encl
1													
2													
3													
4													
5													

ACCESSORY ITEMS	1	2	3	4	5	ACCESSORY ITEMS	1	2	3	4	5
<input type="checkbox"/>						<input type="checkbox"/>					
<input type="checkbox"/>						<input type="checkbox"/>					
<input type="checkbox"/>						<input type="checkbox"/>					
<input type="checkbox"/>						<input type="checkbox"/>					
<input type="checkbox"/>						<input type="checkbox"/>					

Project: _____ Submitted: _____
 Customer: _____ Approved: _____
 Location: _____