

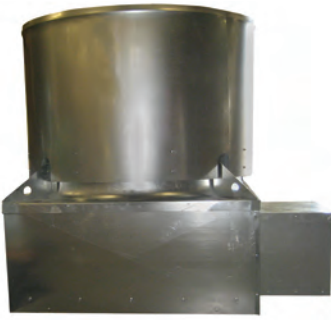

MODEL UBSRD

REMOTE DRIVE UPBLAST PROPELLER ROOF EXHAUSTER



MODEL FEATURES

- Exhaust air up to 52,000 CFM in static pressure applications up to 3/4" w.g.
- Motor and drives are located outside of the exhaust airstream
- Suited for removal of heated or contaminated air
- Capable of continuous operation exhausting air up to 200°F
- Belt drives permit easy performance adjustments when needed
- cULus 705 Listed

MODEL OVERVIEW

Model UBSRD units are high capacity, belt driven roof mounted exhausters rated from 4,900 to 52,000 CFM. The motor and drives are located outside of the exhaust airstream, making these units especially suited for the removal of heated or contaminated air from commercial and industrial buildings or processes where these conditions exist. All models are capable of continuous operation exhausting air to 200°F.

The remote drive construction allows for easy rooftop belt and motor access for maintenance. For increased air performance (in clean conditions) with the same easy maintenance access, the UBSRD is available without the belt and bearing enclosures.

Straight-through air flow design results in maximum exhaust efficiency. During operation, high air flow velocity opens butterfly dampers and prevents rain or snow from entering. Dampers close and cover the venturi opening when unit is not in use.

The roof mounted location eliminates interference with processes and equipment inside the building. It also permits locating the exhauster over a source of heated or contaminated air, allowing direct upward venting to the outside, unlike wall mounted exhausters which may move contaminated air through adjacent work spaces.

2 year fan housing warranty, 1 year motor warranty



CONSTRUCTION/SPECIFICATION CHECKLIST

Panel Assembly

- Heavy-gauge G90 galvanized steel panel, size 24-60.
- One piece venturi for maximum efficiency and strength.
- Motor mounting plates of heavy-gauge galvanized steel.
- Bearing mounting plates of heavy-gauge galvanized steel.
- Lifting eyes standard for ease of installation.

Windband/Butterfly Dampers

- Heavy-gauge galvanized steel windband.
- Galvanized steel butterfly dampers standard.
- Galvanized rain channel drains water from damper area to roof.
- Galvanized damper shaft rotates in bronze bushing.

Propeller

- Steel hub plate with steel taper lock bushing.
- Die formed, heavy-gauge, epoxy coated, steel blades.

Drives

- Shielded from airstream by galvanized steel enclosure (Optional).
- Sized for minimum 150% of drive horsepower.
- Single belt adjustable pitch sheaves through 3HP.
- Two belt fixed pitch sheaves 5HP through 10HP.
- Adjustable pitch sheaves are optional above 3HP.
- Tilt motor base for belt adjustment.
- Nonstatic, oil resistant v-belts.
- Keyed, turned, ground and polished shafts.

Bearings

- Bearings designed for minimum 200,000 hour life, L50.
- Cast iron self-aligning pillow block ball bearings.
- Bearings are sealed, prelubricated and furnished with relube fittings.

Motors

- Located outside airstream under weather cover.
- Brands are nationally recognized and locally serviced.
- Open drip-proof construction is standard.



OPTIONS/ACCESSORIES

Roof Curb: Prefabricated heavy-gauge galvanized steel, welded construction, 12" high with 1-1/2" wood nailer. Options include burglar bars, single and double pitch construction, and additional curb heights.

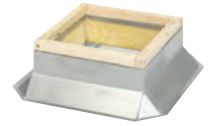

Disconnect Switch: Nonfused safety disconnects are available for all motor sizes in rain-tight or open enclosures.

Magnetic Latches: Help reduce damper chatter when the units are not in operation.

Noninsulated Belt Cover (Belt Tube): To isolate drive components from airstreams.

Outlet Guard: 1/2" x 1" wire mesh guard will prevent birds and other objects from entering fan.

Propeller Blade Side Safety Guard: 1/2 x 1" galvanized wire guard. **Important:** For all nonducted applications, the manufacturer recommends that a safety guard must be installed as a safety precaution for personnel below unit.

Extended Grease Lines: Extended grease lines allow fan bearings to be relubricated from the exterior.

Special Coatings: Powered roof exhausters often require special coatings for protective and decorative purposes. Available coatings include: Synthetic Resin, Epoxy, and Heresite (air-dried phenolic). Contact your representative or the factory for more information on available coatings and colors.

MODELS UBSRD-HT & UBSRD-HT1

REMOTE DRIVE UPBLAST PROPELLER ROOF EXHAUSTERS FOR HEAT AND SMOKE REMOVAL



MODEL FEATURES

- Exhaust air up to 52,000 CFM in static pressure applications up to 3/4" w.g.
- Motor and drives are located outside of the exhaust airstream
- Designed and tested for emergency heat and smoke removal
- Successfully passed heat test of 1000°F for 15 minutes and 500°F for over 4 hours
- Belt drives permit easy performance adjustments when needed
- cULus 705 Listed

MODEL OVERVIEW

Model UBSRD-HT/HT1 has been designed and tested for emergency heat and smoke removal. This design also lends itself to everyday nonemergency high capacity industrial and commercial roof exhaust applications. Model UBSRD-HT/HT1 successfully passed heat test of 1000°F for fifteen (15) minutes, and 500°F for over four (4) hours by an independent testing agency. Model UBSRD-HT/HT1 exceeds I.R.I (Industrial Risk Insurers) guidelines as "Power Ventilator for Smoke Control Systems."

Features	UBSRD-HT	UBSRD-HT1
165°F (74°C) Fusible Link and Spring Damper Lifters		•
Belt tube with heat shield	•	•
Dual Drives	•	•
High Temperature Bearing Grease	•	•

The heavy-gauge design allows for years of standard commercial use and the dependability required in a fire emergency. The upblast configuration exhausts heat and smoke high above the roof line aiding in the access and capabilities of firefighters. Unlike complete design dependence on gravity vents which are sometimes limited by air temperature and wind velocity, the UBSRD-HT/HT1 in conjunction with gravity vents, will more effectively remove smoke, hot air, and gases when used in a properly designed system. With the UBSRD-HT1 unit, in the event of electrical failure, the 165°F fusible link will activate the spring assisted damper doors to provide gravity ventilation. Fan CFM, sizing and location for both exhaust and supply air are an important part of the overall heat and smoke venting building design needs. Refer to I.R.I., NFPA (National Fire Protection Association), and local fire codes for help in proper system design. Final approval for the complete system design should be authorized by the local authority having jurisdiction.

Fan selections are available in 24, 30, 36, 42, 48, 54 and 60 inch sizes. Horsepower and CFM range to 52,000 CFM and 10HP. Units are tested in accordance with AMCA Standard 301 (sound) and AMCA 210 (air) in an AMCA certified laboratory. Every unit is completely assembled and factory tested for quality assurance prior to shipment.

1 year fan housing warranty, 1 year motor warranty



CONSTRUCTION/SPECIFICATION CHECKLIST

1. Successfully heat tested by independent laboratory for;
 - (a) 1000°F for 15 minutes.
 - (b) 500°F for minimum 4 hours.
2. All ferrous construction in airstream.
3. 165°F fusible link in damper spring mechanism (HT1 unit only).
4. Motor out-of-airstream design.
5. Belt & bearings enclosed in ventilated housing.
6. Minimum dual groove drive/belt combination.
7. Shaft heat slinger.
8. Belt tube and cover standard.
9. Die formed, heavy-gauge, epoxy coated, steel blades.
10. High temp grease.

Drives

Motors, bearings and belt are shielded from the airstream by a sheet metal enclosure, with cooling provided by fresh outside air. Drives are fixed, sized for a minimum 150% of drive horsepower. Drives are minimum dual groove sheaves. Adjustable sheaves are available as an option. Bearings are heavy-duty cast iron, pillow block with relubricable fittings. Standard bearings are designed for minimum 200,000 hour, L50 life. All shafts are turned, ground and polished steel coated with an anti-rust compound to resist corrosion.

Electrical Power

Electrical power should be independent of the general building. Wiring requires special, heat resistant qualities as determined by local fire codes. Switching should always be arranged so that automatic start-up can be achieved through safety devices such as, but not limited to, sprinkler systems and smoke or heat sensors.

High Temperature Option

500°F (260°C) for a minimum of 4 hours

1000°F (538°C) for a minimum of 15 minutes

This construction exceeds specifications for IRI requirements of 500°F (260°C) air for a minimum of 4 hours and the SBCCI “Standard Fire Prevention Code” requirements of 1000°F (538°C) for a minimum of 15 minutes in emergency smoke removal applications. In addition, this construction exceeds British Standards 7346 Class B (250°C for 2 hours), Class C (300°C for 15 minutes), and Class D (300°C for 1 hour) temperature requirements. Temperature ratings tested in accordance to UL smoke control systems.

OPTIONS/ACCESSORIES

Roof Curb: Prefabricated heavy-gauge galvanized steel, welded construction, 12” high with 1-1/2” wood nailer. Options include burglar bars, single and double pitch construction, and additional curb heights.

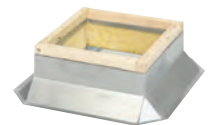

Disconnect Switch: Nonfused safety disconnects are available for all motor sizes in rain-tight or open enclosures.

Outlet Guard: 1/2” x 1” wire mesh guard will prevent birds and other objects from entering fan.

Propeller Blade Side Safety Guard: ½ x 1” galvanized wire guard. **Important:** For all nonducted applications, the manufacturer recommends that a safety guard must be installed as a safety precaution for personnel below unit.

Special Coatings: Powered roof exhausters often require special coatings for protective and decorative purposes. Available coatings include: Synthetic Resin, Epoxy, and Heresite (air-dried phenolic). Contact your representative or the factory for more information on available coatings and colors.



PERFORMANCE DATA

Model	Motor HP	RPM	Max. BHP	Sones @ .375	CFM @ Static Pressure in Inches of Water											
					0.000	0.100	0.125	0.150	0.200	0.250	0.300	0.375	0.500	0.625	0.750	
24L	1/2	989	0.55	17	6153	5747	5645	5511	5244	4977						
	3/4	1123	0.82	22	6987	6629	6539	6435	6227	6019	5761	5373				
	1	1233	1.1	23	7671	7345	7263	7179	7012	6845	6614	6267	5580			
	1-1/2	1415	1.65	28	8800	8516	8445	8374	8231	8089	7920	7667	7163	6593		
30L	3/4	850	0.82	17	10257	9359	9134	8795	8118	7440						
	1	931	1.1	21	11224	10426	10227	9950	9396	8842	7950	6611				
	1-1/2	1065	1.65	25	12847	12189	12024	11814	11394	10974	10397	9531	7404			
	2	1180	2.2	29	14235	13675	13535	13350	12979	12608	12176	11529	10119			
30H	2	1286	2.2	34	13082	12604	12484	12364	12125	11886	11594	11156				
	3	1470	3.3	47	14959	14541	14436	14331	14122	13912	13690	13357	12706			
	5	1736	5.5	49	17664	17310	17221	17132	16955	16778	16601	16335	15874	15322	14697	
36L	1	641	1.1	21	13232	12196	11937	11622	10991	10361	6217					
	1-1/2	727	1.65	25	15018	14137	13917	13661	13148	12636	11969	10969				
	2	810	2.2	29	16726	15936	15738	15516	15071	14626	14145	13423				
	3	926	3.03	36	19128	18437	18264	18080	17713	17345	16943	16340	15239			
36H	3	1016	3.3	41	19050	18274	18080	17870	17449	17029	16556	15846	14267	12076		
	5	1205	5.5	57	22599	21945	21781	21615	21282	20950	20583	20032	19094	17763	16282	
42L	1	495	1.1	23	15823	13994	13537	12974	11847							
	1-1/2	562	1.65	28	17965	16347	15942	15487	14576	13666						
	2	623	2.2	35	19920	18453	18086	17707	16950	16192						
	3	711	3.3	38	22724	21438	21116	20801	20170	19539	18804	17702				
	5	784	4.5	42	25056	23890	23598	23310	22733	22157	21549	20638	18853			
42H	5	1004	5.5	50	26457	25702	25513	25288	24839	24389	23890	23141	21942	20643	18996	
	7-1/2	1155	7.88	53	30440	29784	29620	29454	29121	28788	28339	27665	26596	25568	24449	
48L	1-1/2	460	1.65	22	21919	19765	19227	18470	16957	15444						
	2	514	2.2	23	24507	22581	22100	21504	20311	19119						
	3	579	3.3	26	27616	25907	25480	25004	24053	23102	21872	20026				
	5	670	5.1	33	31937	30459	30090	29721	28982	28243	27308	25905	23195	20385		
48H	5	791	5.5	40	32797	30939	30474	30136	29461	28786	27950	26696	24225			
	7-1/2	908	8.25	48	37629	35906	35475	35172	34565	33958	33369	32486	30522	28440		
	10	970	10.1	50	40214	38602	38199	37896	37289	36682	36131	35305	33727	31778	29735	
54L	1-1/2	402	1.65	16	24586	21026	20136									
	2	442	2.2	17	27060	23788	22970	21627	18942	16256						
	3	504	3.3	19	30851	27673	26879	26109	24570	23031	20309	16227				
	5	600	5.5	25	36726	33989	33305	32818	31844	30870	29178	26640	20018			
54H	3	633	3.3	37	30726	28700	28194	27748	26856	25964	24765	22967				
	5	771	5.5	51	37430	35799	35391	34990	34187	33385	32652	31553				
	7-1/2	882	8.25	54	42804	41386	41032	40659	39912	39165	38537	37596	35925			
	10	939	10.5	57	45565	44233	43900	43553	42858	42163	41533	40589	39167	37334	35314	
60L	3	418	3.3	24	37362	33644	32715	31036	27677	24318	21876	18214				
	5	495	5.49	26	44233	41132	40357	39495	37771	36047	32622	27485	22405			
60H	7-1/2	555	8.15	35	50459	47741	47062	46356	44943	43530	41464	38364	30821	26382		
	3	564	3.3	37	36030	33791	33231	32388	30702	29016						
	5	664	5.5	47	42397	40441	39952	39405	38310	37216	35553	33058				
	7-1/2	744	8.25	51	47555	45805	45368	44965	44160	43354	41982	39924	36140	32640	27799	
	10	817	10.5	54	52173	50579	50180	49803	49048	48293	47339	45907	42619	39077	35879	

Performance shown is for roof ventilators for installation type A: Free inlet, Free outlet. The power rating (BHP) does not include drive losses. Performance ratings do not include the effects of appurtenances in the airstream.

Sound ratings are loudness values in fan sones at 5 feet (1.5m) in a hemispherical free field calculated per AMCA Standard 301. Values are for installation type A: Free inlet fan sone levels.

Due to air stream cooling, the motor loading into the service factor shown does not overheat the motor and is within NEMA recommended limits. BHP at most static pressure points is less than the maximum power shown - in many cases substantially less. Please refer to the Optimizer Selection Program for additional sound data and for selections at other static pressures, and to see the exact BHP for your selection.





DIMENSIONS

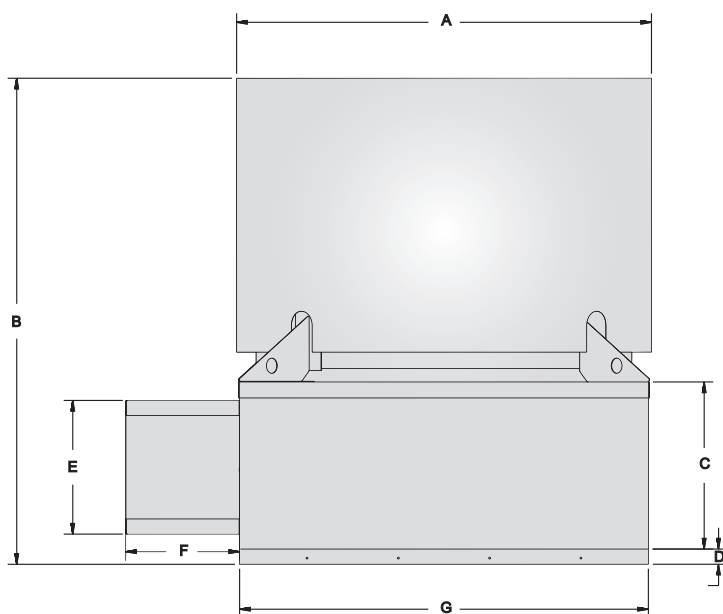

Model Number Code
 The model number code is designed to completely identify the fan. Below is a detailed explanation of the model number codes:

UBS RD HT - 36 L

Uplblast Propeller Roof Fan (UBS)
 Motor out-of-airstream (RD)
 Level of Construction (HT or HT1) (HT)
 Fan Size (36)
 Propeller Type (L)
 L-Low
 H-High

Model	A	B	C	D	E	F	G	H	I	Wt. (lbs)
24	30	49	22	2	17-1/2	15	29-1/2	28-1/2	25-1/2	310
30	36	52	22	2	17-1/2	15	35-1/2	34-1/2	31-1/2	340
36	42	58	22	2	17-1/2	15	41-1/2	40-1/2	37-1/2	430
42	48	61	22	2	17-1/2	15	47-1/2	46-1/2	43-1/2	490
48	54	64	22	2	17-1/2	15	53-1/2	52-1/2	49-1/2	640
54	60	67	22	2	17-1/2	15	59-1/2	58-1/2	55-1/2	840
60	66	70	22	2	17-1/2	15	65-1/2	64-1/2	61-1/2	1000

- A - Outside Diameter Windband
- B - Total Height of Unit
- C - Housing Height
- D - Curb Cap Depth
- E - Motor Cover Height
- F - Motor Cover Width
- G - Inside Dimension of Square Curb Cap
- H - OD of factory built prefab curb.
- I - Recommended roof opening (inside dimension of factory built prefab curb.)

Model	Windband (galv)	Curb Cap (Galv)	Butterfly Damper		Housing (galv) Front/Back	Drive Support Channel	Channel Support	Motor Bracket	Drive Shaft Size	Max Motor Frame Size
			Galv	Alum						
24	20	14	20	0.04	18	12	12	10	1	145T
30	20	14	20	0.04	18	12	12	10	1	184T
36	20	14	20	0.04	18	12	12	10	1	184T
42	20	14	20	0.04	18	12	12	10	1-7/16	215T
48	20	14	20	0.04	18	12	12	10	1-7/16	215T
54	20	14	20	0.04	18	12	12	10	1-7/16	215T
60	20	14	20	0.04	18	12	12	10	1-7/16	215T