

MODEL TUB-HT

TUBEAXIAL UPBLAST PROPELLER ROOF EXHAUSTER FOR HEAT AND SMOKE REMOVAL



MODEL FEATURES

- Exhaust air up to 57,000 CFM in static pressure applications up to 3/4" w.g.
- Motor and drives are located outside of the exhaust airstream
- Designed and tested for emergency heat and smoke removal
- Successfully passed heat test of 1000°F for 15 minutes and 500°F for over 4 hours
- Belt drives permit easy performance adjustments when needed
- UL 793 Listed as Power Ventilator for Smoke Control Systems

MODEL OVERVIEW

Model TUB-HT has been designed and tested for emergency heat and smoke removal. This design also lends itself to everyday nonemergency high capacity industrial and commercial roof exhaust applications. Model TUB-HT successfully passed heat test of 1000°F for fifteen (15) minutes, and 500°F for over four (4) hours by an independent testing agency. Model TUB-HT exceeds I.R.I (Industrial Risk Insurers) guidelines and is UL-793 Listed as "Power Ventilator for Smoke Control Systems."

The heavy-gauge design allows for years of standard commercial use and the dependability required in a fire emergency. The upblast configuration exhausts heat and smoke high above the roof line aiding in the access and capabilities of fire fighters. Unlike complete design dependence on gravity vents which are sometimes limited by air temperature and wind velocity, the TUB-HT in conjunction with gravity vents, will more effectively remove smoke, hot air, and gases when used in a properly designed system. In the event of electrical failure, the 165°F fusible link will activate the spring assisted damper doors to provide gravity ventilation. Fan CFM, sizing and location for both exhaust and supply air are an important part of the overall heat and smoke venting building design needs. Refer to I.R.I., NFPA (National Fire Protection Association), and local fire codes for help in proper system design. Final approval for the complete system design should be authorized by the local authority having jurisdiction.

Fan selections are available in 24, 30, 36, 42, 48, 54 and 60 inch sizes. Horsepower and CFM range to 57,000 CFM and 15HP. Units are tested in accordance with AMCA Standard 301 (sound) and AMCA 210 (air) in an AMCA certified laboratory. Every unit is completely assembled and factory tested for quality assurance prior to shipment.

1 year fan housing warranty, 1 year motor warranty



CONSTRUCTION/SPECIFICATION CHECKLIST

1. Successfully heat tested by independent laboratory for:
 - (a) 1000°F for 15 minutes.
 - (b) 500°F for minimum 4 hours.
2. All ferrous construction in airstream.
3. 165°F fusible link in damper mechanism (heat & smoke vent).
4. Motor out-of-airstream design.
5. Belt & bearings enclosed in ventilated housing.
6. Minimum dual groove drive/belt combination.
7. Shaft heat slinger.
8. Extended lubrication lines.
9. UL-793 Listed Power Ventilator for Smoke Control Systems.
10. Meets UL-793 snow load test.

Drives

Motors, bearings and belt are shielded from the airstream by a sheet metal enclosure, with cooling provided by fresh outside air. Drives are sized for a minimum 150% of drive horsepower. Drives are minimum dual groove sheaves through 10 horsepower and three-belt on 15HP. Adjustable sheaves are available as an option. Bearings are heavy-duty cast iron, pillow block with relubricable fittings. Standard bearings are fitted with remote relubricable fittings and designed for minimum 200,000 hour life. All shafts are turned, ground and polished steel coated with an anti-rust compound to resist corrosion.

Electrical Power

Electrical power should be independent of the general building. Wiring requires special, heat resistant qualities as determined by local fire codes. Switching should always be arranged so that automatic start-up can be achieved through safety devices such as, but not limited to, sprinkler systems and smoke or heat sensors.

OPTIONS/ACCESSORIES

Roof Curb: Prefabricated heavy-gauge galvanized steel, welded construction, 12" high with 1-1/2" wood nailer. Options include burglar bars, single and double pitch construction, and additional curb heights.

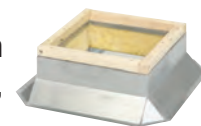

Outlet Guard: 1/2" x 1" wire mesh guard will prevent birds and other objects from entering fan.

Inspection Door: For inspection and blade service/cleaning.

Disconnect Switch: Nonfused safety disconnects are available for all motor sizes in rain-tight or open enclosures.

Special Coatings: Powered roof exhausters often require special coatings for protective and decorative purposes. Available coatings include: Synthetic Resin, Epoxy, and Heresite (air-dried phenolic). Contact your representative or the factory for more information on available coatings and colors.



DIMENSIONS

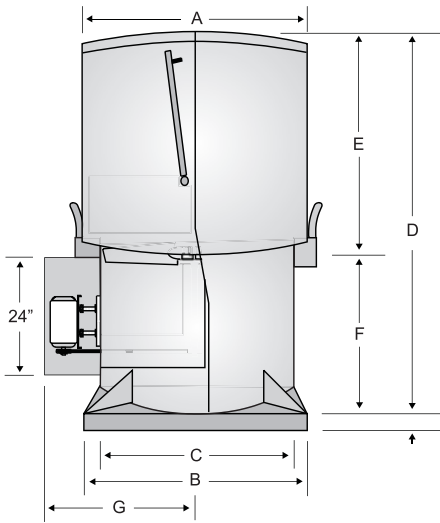

Model TUB-HT	Dimensions (Inches)						
	A O.D. Windband	B sq. I.D. Curb Cap	C sq. Min. I.D. Opg	D Height	E Windband Height	F Tube Height	G (Max.)
24	30	35	25-1/8	55-1/2	25	30-1/2	37
30	36	41	31-1/8	58-1/2	28	30-1/2	40
36	42	47	37-1/8	60-1/2	30	30-1/2	43
42	48	53	43-1/8	65-1/2	33	32-1/2	46
48	54	59	49-1/8	68-1/2	36	32-1/2	49
54	60	65	55-1/8	71-1/2	39	32-1/2	52
60	66	71	61-1/8	74-1/2	42	32-1/2	55

Model TUB-HT	Metal Gauges			Average Weight
	Fan Housing	Wind Shroud	Curb Cap	
24	12	18	14	500
30	12	18	14	600
36	12	18	14	1000
42	12	18	14	1100
48	10	18	14	1300
54	10	18	14	1580
60	10	18	10	1700

**PERFORMANCE DATA****TUB-HT - Belt Drive - Steel Blade**

Model TUB-HT	CFM / BHP @ Static Pressure							HP	RPM	Max. BHP	Sones @ 5 ft.
	0	1/8	1/4	3/8	1/2	5/8	3/4				
24	6255	5297	4821	4035	-	-	-	3/4	1215	0.78	21
	6962	6547	6115	5446	-	-	-	1	1275	1.08	25
	7896	7272	6601	6216	5814	5248	-	1-1/2	1530	1.53	31
	8693	8109	7688	7265	6276	5409	-	2	1750	2.05	40
30	9631	8703	6835	6478	-	-	-	1	1180	1.06	26
	11324	10716	9408	7755	6574	-	-	1-1/2	1155	1.57	29
	11952	11272	10694	9776	8405	7824	-	2	1550	2.09	35
	13871	13059	12491	11234	10295	8173	-	3	1325	3.08	34
	16225	15983	15120	14730	12761	10576	8568	5	1560	5.13	42
36	14173	13128	11822	10471	-	-	-	1-1/2	1015	1.61	28
	15114	14353	13243	11988	10514	8772	7444	2	1160	2.11	32
	18020	16740	16186	14342	10549	9510	7865	3	1140	3.05	38
	20849	20157	19368	18978	16490	14118	11362	5	1245	5.12	53
42	18628	17503	15264	12855	11606	-	-	2	930	2.01	29
	22193	20384	18866	17337	15643	13574	-	3	1140	3.13	38
	25960	24822	23667	22374	20839	19521	18043	5	1140	5.07	48
	29490	28518	28186	26569	24926	23934	19623	7-1/2	1140	7.81	58
48	20302	18094	15044	11132	-	-	-	2	655	2.1	29
	27001	25050	22614	18159	12350	-	-	3	745	3.08	32
	29173	27591	25732	23625	21215	17472	-	5	840	5.16	42
	33418	31872	30249	28062	25682	22744	18678	7-1/2	860	7.6	51
	36776	35878	34984	34042	33014	31980	30940	10	1340	10.1	98
54	27348	24097	18041	-	-	-	-	3	530	3.15	29
	34050	31546	28811	24511	18272	-	-	5	640	5.4	39
	42632	40823	38562	36009	29864	23065	-	7-1/2	900	7.55	48
	47064	45427	43602	41604	38006	30622	-	10	860	10.08	52
	49325	48358	47390	45974	42307	37941	34800	15	780	15.71	62
60	35718	32721	24429	19438	-	-	-	3	530	3.11	28
	42487	40061	35933	30065	25302	22050	-	5	640	5.18	35
	48378	45938	43009	38690	35690	30406	-	7-1/2	800	7.59	47
	54617	50622	48428	45938	37363	29993	-	10	845	10.13	53
	57143	54850	52557	50264	47971	42759	35297	15	675	15.61	62

Contact factory for alternate selections if required.

The sound ratings shown are loudness values in fan sones at 5 ft. (1.5m) in a hemispherical free field calculated per AMCA Standard 301 @ free air.

Brake horsepower does not include drive losses.

Values are installation Type A, free inlet fan sone levels.

Performance shown is for types and units without inlet or outlet ducts.



Standard 793
(optional)